

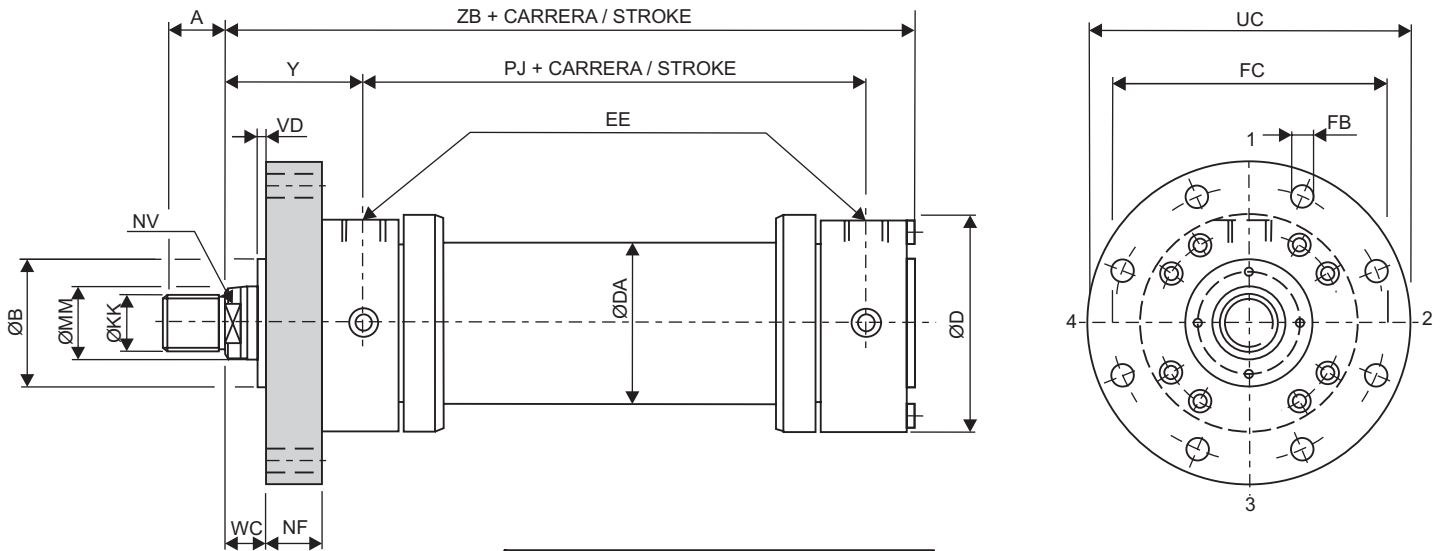

A ISO MF 3

BRIDA DELANTERA FRONT ROUND FLANGE MOUNTING

ISO 6022



Presión nominal
Nominal Pressure **250 bar**

Posición regulador amortiguación, lado 2. Location of cushioning-screw, side 2.

Pistón Ø Bore Ø	50		63		80		100		125		140		160		180		200		250		320		
	MM	32	36	40	45	50	56	63	70	80	90	90	100	100	110	110	125	125	140	160	180	200	220
A		36		45		56		63		85		90		95		105		112		125		160	
B f8		63		75		90		110		132		145		160		185		200		250		320	
D		102		120		145		170		206		226		265		292		306		412		500	
DA		65		78		100		120		150		170		190		210		230		298,5		385	
EE		1/2"G		3/4"G		3/4"G		1"G		1"G		1 1/4"G		1 1/4"G		1 1/4"G		1 1/4"G		1 1/2"G		2"G	
FB H13		8x13,5Ø		8x13,5Ø		8x17,5Ø		8x22Ø		8x22Ø		8x26Ø		8x26Ø		8x33Ø		8x33Ø		8x39Ø		8x45Ø	
FC ±0,2		132		150		180		212		250		280		315		350		385		475		600	
KK		M 27x2		M 33x2		M 42x2		M 48x2		M 64x3		M 72x3		M 80x3		M 90x3		M 100x3		M 125x4		M 160x4	
NF		25		28		32		36		40		40		445		50		56		63		80	
NV		27	30	32	36	41	46	50	60	65	75	75	85	85	95	95	110	110	120	140	160	180	200
PJ		120		133		155		171		205		219		235		264		278		325		350	
UC		155		175		210		250		290		325		360		405		440		540		675	
VD		4		4		4		5		5		5		5		5		5		8		8	
WC		22		25		28		32		36		36		40		45		45		50		56	
Y		98		112		120		134		153		166		185		194		220		260		310	
ZB		244		274		305		340		396		431		467		510		550		652		764	