

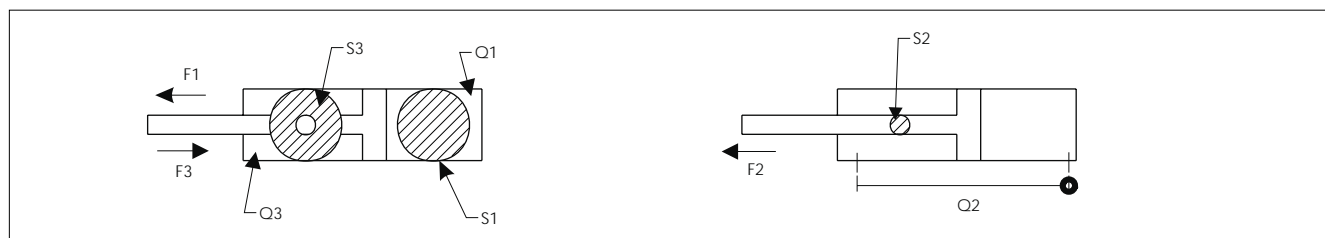

• DETERMINACION DEL CILINDRO •
• DETERMINATION OF THE CYLINDER •

Piston	Vástago	AREAS			Empuje Min	Empuje Max	Fuerza Diferencial	Fuerza Tracción	Caudal Salida	Caudal Diferencial	Caudal Entrada
Bore	Rod				Push Min	Push Max	Force Regen.	Force Pull	Flow Out	Flow Regen.	Flow In
Δ PISTÓN	Δ VTGO	S ₁	S ₂	S ₃	F ₁ (MIN)	F ₁ (MAX)	F ₂	F ₃	Q ₁	Q ₂	Q ₃
mm	mm	cm ²	cm ²	cm ²	kN	kN	kN	kN	l/min	l/min	l/min
25	14	4,91	1,54	3,37	0,74	7,85	2,46	5,39	2,9	0,92	2,0
	18		2,54	2,36			4,07	3,78		1,53	1,4
32	18	8,04	2,54	5,50	1,21	12,86144	4,07	8,79	4,8	1,53	3,3
	22		3,80	4,24			6,08	6,78		2,28	2,5
40	22	12,56	3,80	8,76	1,88	20,096	6,08	14,02	7,5	2,28	5,3
	28		6,15	6,41			9,85	10,25		3,69	3,8
50	28	19,63	6,15	13,47	2,94	31,4	9,85	21,55	11,8	3,69	8,1
	36		10,17	9,45			16,28	15,12		6,10	5,7
63	36	31,16	10,17	20,98	4,67	49,85064	16,28	33,57	18,7	6,10	12,6
	45		15,90	15,26			25,43	24,42		9,54	9,2
80	45	50,24	15,90	34,34	7,54	80,384	25,43	54,95	30,1	9,54	20,6
	56		24,62	25,62			39,39	41,00		14,77	15,4
100	56	78,50	24,62	53,88	11,78	125,6	39,39	86,21	47,1	14,77	32,3
	70		38,47	40,04			61,54	64,06		23,08	24,0
125	70	122,66	38,47	84,19	18,40	196,25	61,54	134,71	73,6	23,08	50,5
	90		63,59	59,07			101,74	94,51		38,15	35,4
160	90	200,96	63,59	137,38	30,14	321,536	101,74	219,80	120,6	38,15	82,4
	110		94,99	105,98			151,98	169,56		56,99	63,6
200	110	314,00	94,99	219,02	47,10	502,4	151,98	350,42	188,4	56,99	131,4
	140		153,86	160,14			246,18	256,22		92,32	96,1
250	140	490,63	153,86	336,77	73,59	785	246,18	538,82	294,4	92,32	202,1
	180		254,34	236,29			406,94	378,06		152,60	141,8
320	180	803,84	254,34	549,50	120,58	1286,144	406,94	879,20	482,3	152,60	329,7
	220		379,94	423,90			607,90	678,24		227,96	254,3

-Tabla1-



Fórmulas empleadas

$$F_1(kN) = \frac{A_1(cm^2) * p(bar)}{100}$$

$$Q_1(l/min) = 6 * v(m/s) * S_1(cm^2)$$

$$F_2(kN) = \frac{A_2(cm^2) * p(bar)}{100}$$

$$Q_2(l/min) = 6 * v(m/s) * S_2(cm^2)$$

$$F_3(kN) = F_1(kN) - F_2(kN)$$

$$Q_3(l/min) = 6 * v(m/s) * S_3(cm^2)$$

Las fuerzas calculadas son teóricas, no se considera la fricción. La velocidad empleada para el cálculo del caudal es de 0.1 m/s y es una velocidad de ejemplo.

The calculated force sare theoretical. Friction has not been taken into account. The speed used for calculating the flow is 0.1m/s , which is just a sample speed.

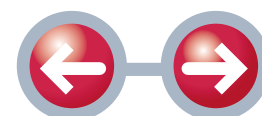

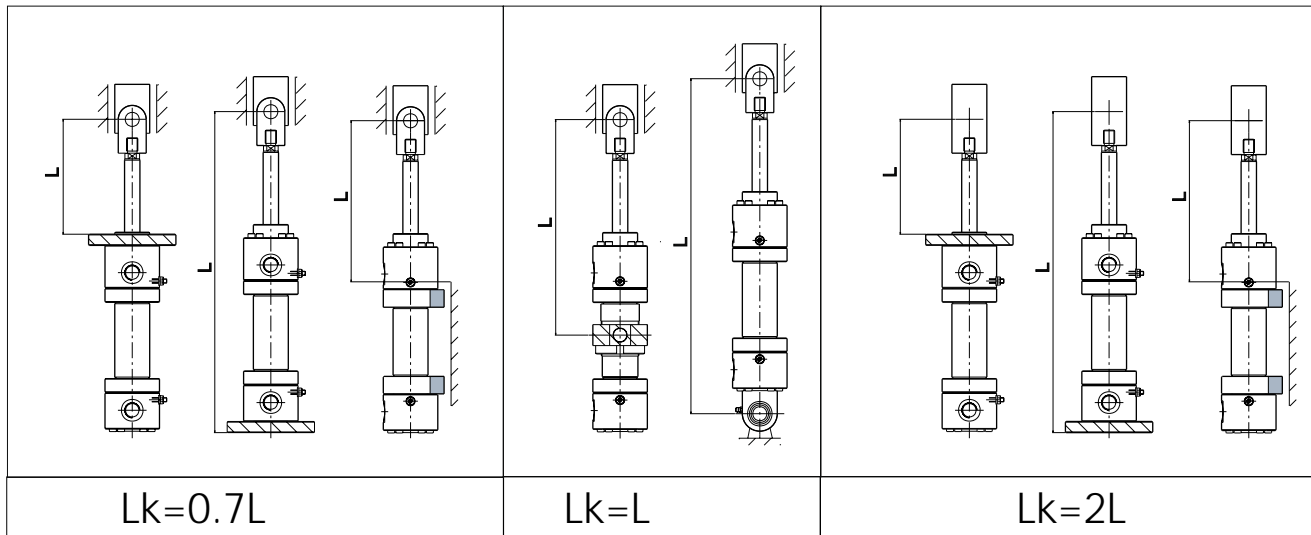

Fig-1

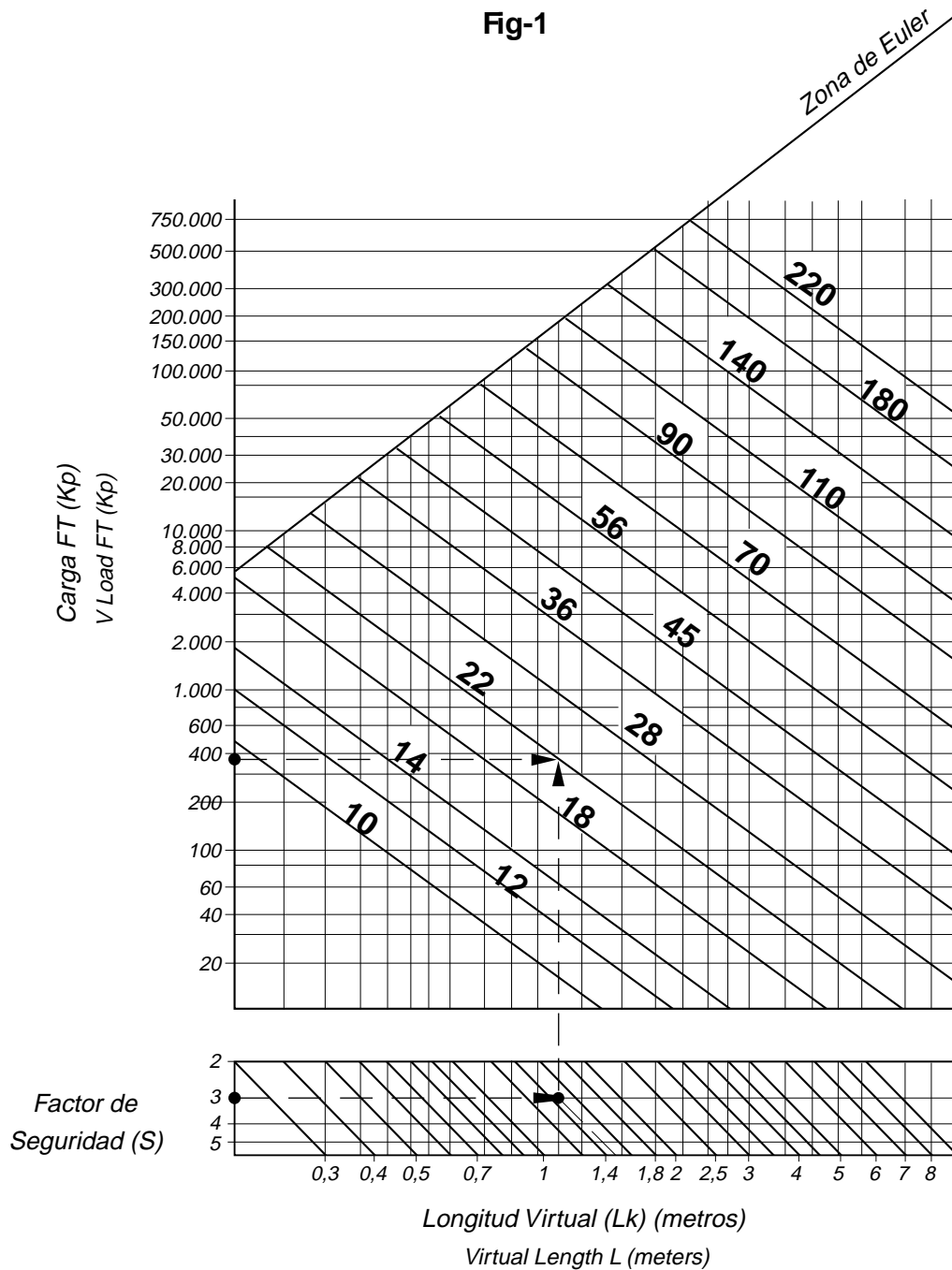
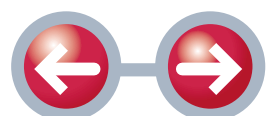

Fig-2





• EJEMPLO DE CÁLCULO •

Supongamos que queremos un cilindro ISO 6020/1 tipo MF2 con rótula ISO 6982 que efectúe una fuerza de empuje $F = 150 \text{ kN} \approx 15300 \text{ kp}$. y que desarrolle una carrera de 1000 mm. de longitud.

Con la tabla de fuerzas (tabla 1) comparamos a que dimensiones se desarrolla la fuerza de 150 kN, esta estaría en un cilindro de diámetro $\varnothing 125$, el cual tiene vástagos de $\varnothing 70$ y $\varnothing 90$, y que necesita una presión

$$\text{teórica de } p = \frac{F_1(\text{kp})}{S_1(\text{cm}^2)} = 124,766 \text{ bar}.$$

Ahora se hará la comprobación de que vástago se necesita para poder aguantar el pandeo según el tipo de fijación del cilindro a la máquina, calculamos la L (longitud entre fijaciones),

$L = ZF + \text{Carrera} + CH = 357 + 1000 + 140 = 1497 \text{ mm}$. , en donde las cotas ZF y CH se obtienen de las tablas interiores de dimensiones del cilindro 125. Con esta medida sacamos la longitud virtual de pandeo (L_k), $L_k = 0.7L$ (Según fig.1) $= 0.7 * 1497 = 1047.9 \text{ mm} \approx 1.1 \text{ m}$.

Nos situamos en la gráfica (fig.2) y con $L_k = 1.1 \text{ m}$., un coeficiente de seguridad 3 y la Fuerza de empuje $F = 15300 \text{ kp}$, hallamos que el mínimo vástago para que no sufra rotura por pandeo debe ser de $\varnothing 36 \text{ mm}$. , como anteriormente nos ha salido $\varnothing 70 \text{ mm}$. y $\varnothing 90 \text{ mm}$., utilizamos el vástago más pequeño aun estando este sobredimensionado.

• EXAMPLE OF CALCULATION •

Let us suppose that we want an ISO 6020/1 cylinder of the MF2 type with an ISO 6982 ball joint with a push force $F = 150 \text{ kN}$. 15300 kp with a course capacity of 1000 mm long.

Using chart 1, we can compare at which dimensions the force of 150 kN is attained. This force would be attained with a cylinder with a diameter of $\varnothing 125$, with $\varnothing 70$ and $\varnothing 90$ rods, and needs a theoretical

$$\text{pressure of } p = \frac{F_1(\text{kp})}{S_1(\text{cm}^2)} = 124,766 \text{ bar}.$$

Now, we must check which rod is most suitable to resist the buckling according to the type of fixture used to join the cylinder to the machine. We calculate L (length between fixtures) $L = ZF + \text{Course} + CH = 357 + 1000 + 140 = 1497 \text{ mm}$, where the dimensions ZF and CH are obtained from the dimension charts of the interior of cylinder number 125. With this measurement, we can now calculate the virtual buckling length (L_k), where $L_k = 0.7L$ (According to pict. 1) $= 0.7 * 1497 = 1047.9 \text{ mm} \approx 1.1 \text{ m}$.

Based on the graph (pict. 2) and taking into account that $L_k = 1.1 \text{ m}$, with a safety coefficient of 3 and a push force $F = 15300 \text{ kp}$, we find out that the minimum rod diameter needed to avoid breakage due to buckling should be of $\varnothing 36 \text{ mm}$. As previously we had $\varnothing 70 \text{ mm}$ and $\varnothing 90 \text{ mm}$., we should then use the smallest rod, even though it is oversized.

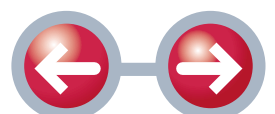



• DESIGNACIÓN CILINDROS REF: CR •

CR-50/36/36-200-X-N-M-N-G-

A-01

TIPO

PISTON

VASTAGO

DOBLE VASTAGO

LONGITUD CARRERA

FIJACION

X - CILINDRO BASE
N - MF1 BRIDA RECTANGULAR DELANTERA
P - MF2 BRIDA RECTANGULAR TRASERA
A - MF3 BRIDA CIRCULAR DELANTERA
B - MF4 BRIDA CIRCULAR TRASERA
D - MP3 CHARNELA MACHO
G - MP5 CHARNELA RÓTULA
E - MS2 PATAS
F - MT4 MUÑON INTERMEDIO

SERIE

POS.CONEXION



A - ESTÁNDAR

CONEXION

G - BSP / GAS / ISO 228/1
M - METRICA
S - ISO/DIS 6162.2
N - NPT

ROSCA VÁSTAGO

N - ROSCA NORMAL
R - ROSCA REFORZADA

M - JUNTAS ESTÁNDAR

W - JUNTAS BAJA FRICCIÓN

T - JUNTAS VITON

JUNTAS

AMORTIGUACIÓN

N - SIN AMORTIGUACIÓN
V - AMORTIGUACIÓN DELANTERA
Z - AMORTIGUACIÓN TRASERA
K - DOBLE AMORTIGUACION

-PARA INCLUIR TRANSDUCTORES O DETECTORES PONERSE EN CONTACTO CON OFICINA TÉCNICA.

-EL VÁSTAGO ESTÁNDAR DE ESTOS CILINDROS ES CROMO DURO. POSIBLE FABRICACIÓN CON OTRO TIPO DE MATERIALES CONTACTAR CON OFICINA TÉCNICA.

• MODEL CODE FOR CR CYLINDERS •

CR-50/36/36-200-X-N-M-N-G-

A-01

TYPE

BORE

ROD

DOUBLEROD

STROKE

ATTACHMENTS

X - BORECILINDER
N - MF1 HEAD RECTANGULAR FLANGE MOUNTING
P - MF2 CAP RECTANGULAR FLANGE MOUNTING
A - MF3 HEAD CIRCULAR FLANGE MOUNTING
B - MF4 CAP CIRCULAR FLANGE MOUNTING
D - MP3 CAP FIXED EYE MOUNTING
G - MP5 SPHERICAL EYE MOUNTING
E - MS2 FOOT MOUNTING
F - MT4 INTERMEDIATE TRUNION

SERIES

CONNECTION POS.



A - STANDARD

CONNECTION

G - BSP / GAS / ISO228/1
M - METRIC
S - ISO/DIS6162.2
N - NTP

ROD EXTREMITIES

N - NORMAL ROD
R - STRENGTHENED ROD

M - STANDARD SEAL

T - REDUCED FRICTION

V - VITON SEAL

SEALS

CUSHIONING

N - NOT CUSHIONED
V - FRONT ONLY
Z - REAR ONLY
K - FRONT AND REAR

- IF TRANSDUCERS OR DETECTING DEVICES ARE REQUIRED, PLEASE CONTACT OUR TECHNICAL OFFICE.

- THE STANDARD ROD USED WITH THIS TYPE OF CYLINDER IS MADE OF HARD CHROMIUM. FOR RODS MADE OF OTHER TYPES OF MATERIALS, PLEASE CONTACT OUR TECHNICAL OFFICE.

Volver
Series Fabricación

Volver
Página Principal

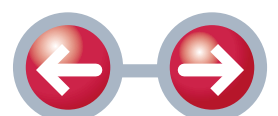

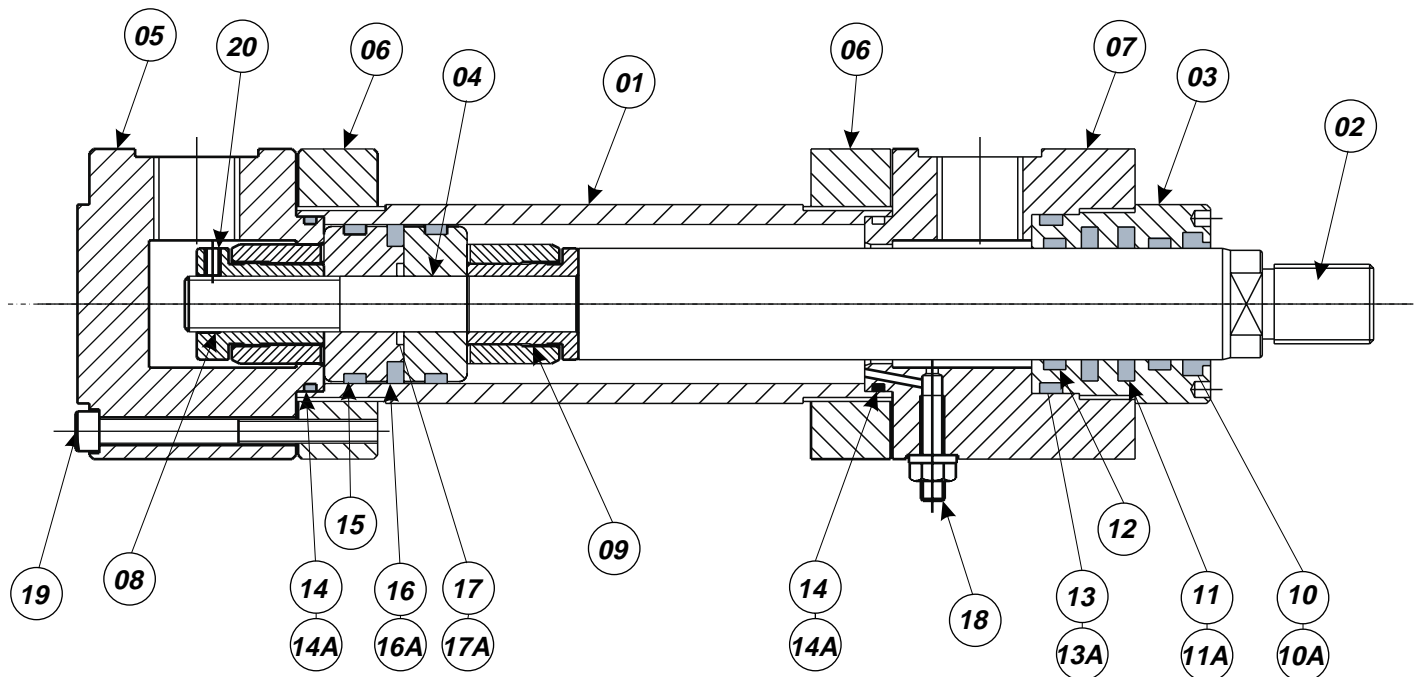

DESCRIPCIÓN	
01	Camisa
02	Vástago
03	Guía vástago
04	Pistón
05	Cabezal Trasero
06	Brida
07	Cabezal delantero
08	Amortiguación Trasera
09	Amortiguación Delantera
10	Rascador ISO 6195 C - Tipo M-T
10A	Rascador Vitón ISO 6195 C- Tipo V
11	J. Vástago ISO 7425/2 - Tipo M-T
11A	J. Vástago Vitón ISO 7425/2 - Tipo V
12	Guía PTFE ISO 10766
13	Torica Guía + Aro de Apoyo - Tipo M-T
13A	Torica Guía + Aro de Apoyo Vitón - Tipo V
14	Junta Tórica - Tipo M-T
14A	Junta Tórica Vitón - Tipo V
15	Guía PTFE ISO 10766
16	Junta Pistón ISO 7425/1 - Tipo M-T
16A	Junta Pistón Vitón ISO 7425/1 - Tipo V
17	Junta Tórica Piston - Tipo M-T
17A	Junta Tórica Piston Vitón - Tipo V
18	Regulador Amortiguación
19	Tornillo DIN 912
20	Prisionero DIN 913

DESCRIPTION	
01	Cylinder housing
02	Rod
03	Rod guiderings
04	Piston
05	Ear cylinder head
06	Flange
07	Forward cylinder head
08	Rear cushioning
09	Forward cushioning
10	Wiper ISO 6195 C - Type M-T
10A	Wiper Viton ISO 6195 C -Type V
11	Rod Seal ISO 7425/2 - Type M-T
11A	Rod Seal Viton ISO 7425/2 - Type V
12	Guide PTFE ISO 10766
13	O-ring Seal + Supportring - Type M-T
13A	O-ring Seal + Supportring - Viton - TypeV
14	O-ring Seal - Type M-T
14A	O-ring Seal Viton - Type V
15	Guide PTFE ISO 10766
16	Piston Seal ISO 7425/1 - Type M-T
16A	Piston Seal Viton ISO 7425/1 - Type V
17	O-ring Seal - Type M-T
17A	O-ring Seal Viton - Type V
18	Cushion adjustment screw
19	Spring washer DIN 912
20	Screw stop pin DIN 913

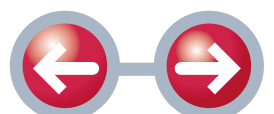



• TIPO - TYPE: AS - MF3 •
BRIDA DELANTERA CIRCULAR
HEAD CIRCULAR FLANGE MOUNTING

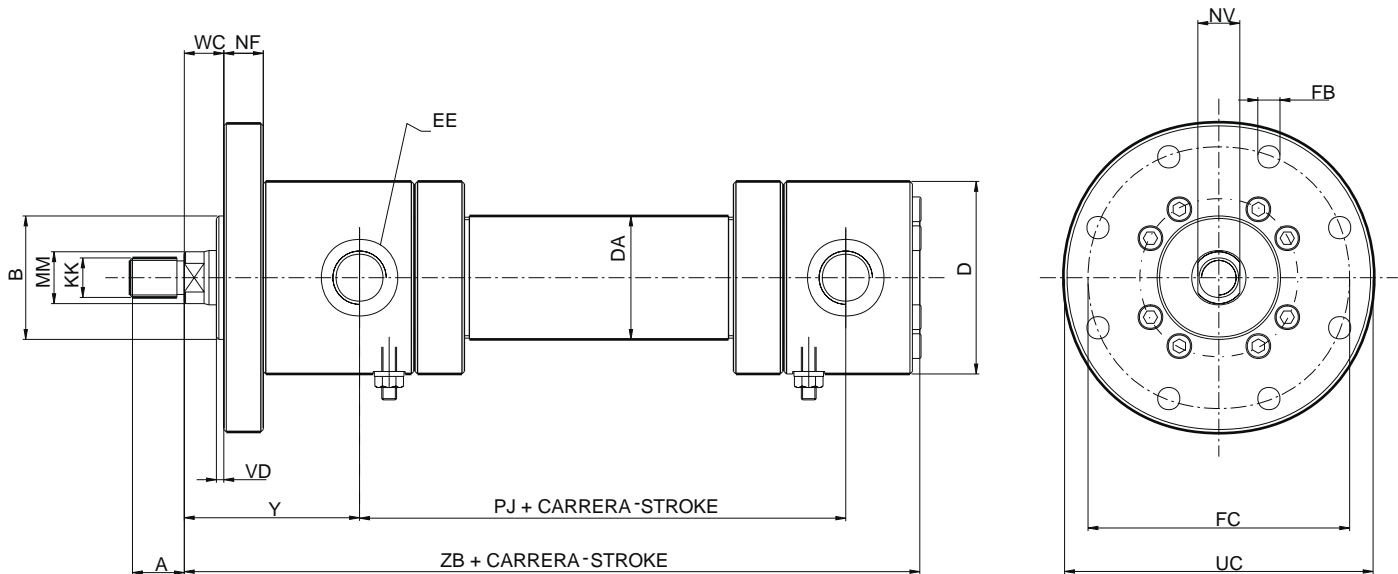

PISTON BORE	MM	A	B _{f8}	D	DA	EE	FB _{H13}	FC _{Js13}	KK	NF	NV	PJ	UC	VD	WC	Y	ZB
25	14	16	32	56	35	1/4"G	6,6	75	M12x1.25	12	12	77	90	3	16	58	155
	18	18							M14x1.5		15						
32	18	18	40	67	42	3/8"G	9	92	M14x1.5	16	15	89	110	3	16	64	176
	22	22							M16x1.5		17						
40	22	22	50	78	50	1/2"G	9	106	M16x1.5	16	17	97	125	3	16	71	198
	28	28							M20x1.5		22						
50	28	28	60	95	60	1/2"G	11	126	M20x1.5	20	22	111	148	4	18	72	213
	36	36							M27x2		28						
63	36	36	70	116	75	3/4"G	13,5	145	M27x2	25	28	117	170	4	20	82	234
	45	45							M33x2		36						
80	45	45	85	130	95	3/4"G	17,5	165	M33x2	32	36	134	195	4	22	91	260
	56	56							M42x2		46						
100	56	56	106	158	115	1"G	22	200	M42x2	32	46	162	238	5	25	108	310
	70	63							M48x2		60						
125	70	63	132	192	145	1"G	22	235	M48x2	32	60	174	272	5	28	121	335
	90	85							M64x3		75						
160	90	85	160	232	185	1 1/4"G	22	280	M64x3	36	75	191	316	5	30	143	380
	110	95							M80x3		90						
200	110	95	200	285	230	1 1/4"G	26	340	M80x3	40	90	224	385	5	35	190	474
	140	112							M100x3		120						
250	140	112	250	365	298	1 1/2"G	33	420	M100x3	56	120	290	500	8	40	205	580
	180	125							M125x4		160						
320	180	125	320	450	368	1 1/2"G	39	520	M125x4	63	160	358	620	8	45	250	696
	220	160							M160x4		200						

CILCOIL, S.A. - se reserva el derecho de modificar: Técnica, material, cotas y formas sin previo aviso.

CILCOIL, S.A. - reserves the rights to modify: Techniques, materials, dimensions and shapes without prior notice.

Volver
Series Fabricación

Volver
Página Principal

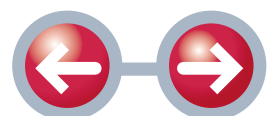



• TIPO - TYPE: BS - MF4 •
BRIDA TRASERA CIRCULAR
CAP CIRCULAR FLANGE MOUNTING

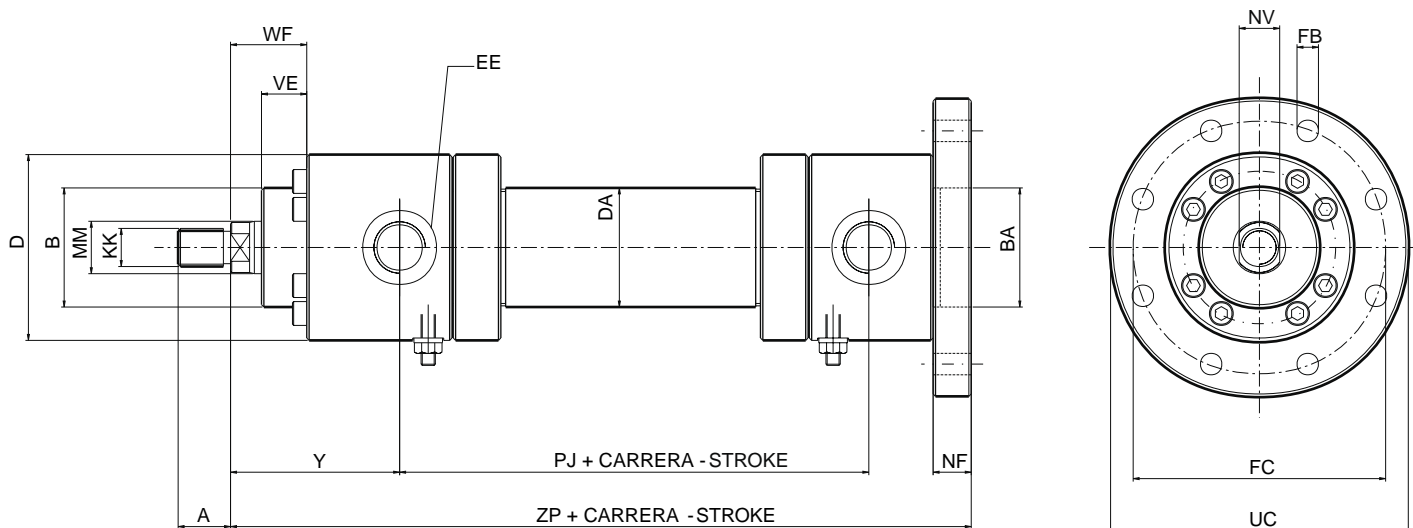

PISTON BORE	MM	A	B _{f8}	BA _{H8}	D	DA	EE	FB _{H13}	FC _{Js13}	KK	NF	NV	PJ	UC	VE	WF	Y	ZP
25	14	16	32	32	56	35	1/4"G	6,6	75	M12x1.25	12	12	77	90	15	28	58	162
	18	18								M14x1.5		15						
32	18	18	40	40	67	42	3/8"G	9	92	M14x1.5	16	15	89	110	19	32	64	186
	22	22								M16x1.5		17						
40	22	22	50	50	78	50	1/2"G	9	106	M16x1.5	16	17	97	125	19	32	71	206
	28	28								M20x1.5		22						
50	28	28	60	60	95	60	1/2"G	11	126	M20x1.5	20	22	111	148	24	38	72	225
	36	36								M27x2		28						
63	36	36	70	70	116	75	3/4"G	13,5	145	M27x2	25	28	117	170	29	45	82	249
	45	45								M33x2		36						
80	45	45	85	85	130	95	3/4"G	17,5	165	M33x2	32	36	134	195	36	54	91	282
	56	56								M42x2		46						
100	56	56	106	106	158	115	1"G	22	200	M42x2	32	46	162	238	37	57	108	332
	70	63								M48x2		60						
125	70	63	132	132	192	145	1"G	22	235	M48x2	32	60	174	272	37	60	121	357
	90	85								M64x3		75						
160	90	85	160	160	232	185	1 1/4"G	22	280	M64x3	36	75	191	316	41	66	143	406
	110	95								M80x3		90						
200	110	95	200	200	285	230	1 1/4"G	26	340	M80x3	40	90	224	385	45	75	190	490
	140	112								M100x3		120						
250	140	112	250	250	365	298	1 1/2"G	33	420	M100x3	56	120	290	500	64	96	205	606
	180	125								M125x4		160						
320	180	125	320	320	450	368	1 1/2"G	39	520	M125x4	63	160	358	620	71	108	250	723
	220	160								M160x4		200						

CILCOIL, S.A. - se reserva el derecho de modificar: Técnica, material, cotas y formas sin previo aviso.

CILCOIL, S.A. - reserves the rights to modify: Techniques, materials, dimensions and shapes without prior notice.

Volver
Series Fabricación

Volver
Página Principal

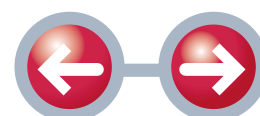



• TIPO - TYPE: NS - MF1 •

BRIDA DELANTERA RECTANGULAR
HEAD RECTANGULAR FLANGE MOUNTING

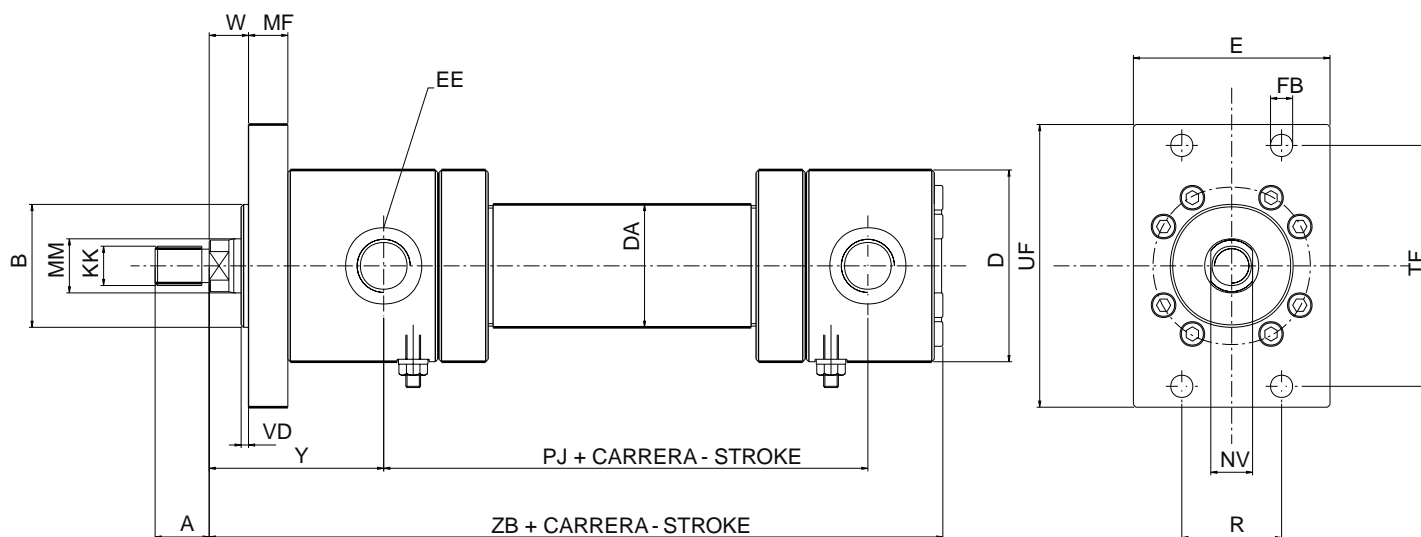

PISTON BORE	MM	A	B _{f8}	D	DA	E	EE	FB _{H13}	KK	MF	NV	PJ	R _{js13}	TF _{js13}	UF	VD	W	Y	ZB
25	14	16	32	56	35	60	1/4"G	6,6	M12x1.25	12	12	77	28,7	69,2	85	3	16	58	155
	18	18							M14x1.5		15								
32	18	18	40	67	42	70	3/8"G	9	M14x1.5	16	15	89	35,2	85	105	3	16	64	176
	22	22							M16x1.5		17								
40	22	22	50	78	50	80	1/2"G	9	M16x1.5	16	17	97	40,6	98	115	3	16	71	198
	28	28							M20x1.5		22								
50	28	28	60	95	60	100	1/2"G	11	M20x1.5	20	22	111	48,2	116,4	140	4	18	72	213
	36	36							M27x2		28								
63	36	36	70	116	75	120	3/4"G	13,5	M27x2	25	28	117	55,5	134	160	4	20	82	234
	45	45							M33x2		36								
80	45	45	85	130	95	135	3/4"G	17,5	M33x2	32	36	134	63,1	152,5	185	4	22	91	260
	56	56							M42x2		46								
100	56	56	106	158	115	160	1"G	22	M42x2	32	46	162	76,5	184,8	225	5	25	108	310
	70	63							M48x2		60								
125	70	63	132	192	145	195	1"G	22	M48x2	32	60	174	90,2	217,1	255	5	28	121	335
	90	85							M64x3		75								

CILCOIL, S.A. - se reserva el derecho de modificar: Técnica, material, cotas y formas sin previo aviso.

CILCOIL, S.A. - reserves the rights to modify: Techniques, materials, dimensions and shapes without prior notice.

Volver
Series Fabricación

Volver
Página Principal

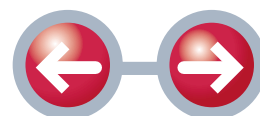



• TIPO - TYPE: PS - MF2 •
BRIDA TRASERA CIRCULAR
CAP CIRCULAR FLANGE MOUNTING

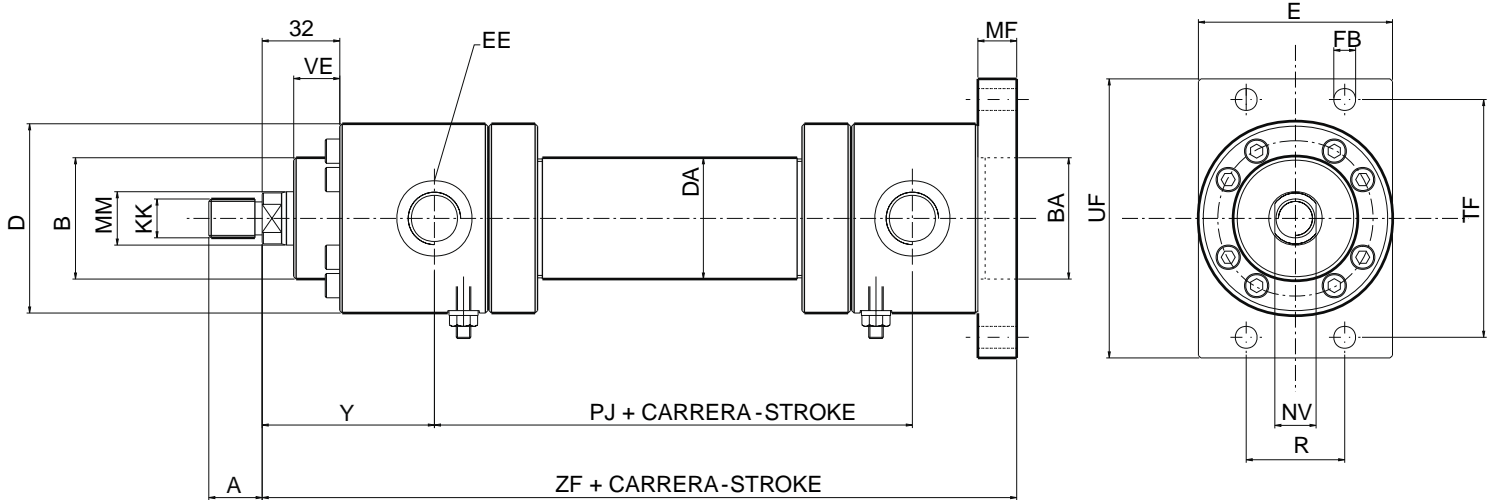

PISTON BORE	MM	A	B _{f8}	BA _{H8}	D	DA	E	EE	FB _{H13}	KK	MF	NV	PJ	R _{js13}	TF _{js13}	UF	VE	WF	Y	ZF
25	14	16	32	32	56	35	60	1/4"G	6,6	M12x1.25	12	12	77	28,7	69,2	85	15	28	58	162
	18	18								M14x1.5		15								
32	18	18	40	40	67	42	70	3/8"G	9	M14x1.5	16	15	89	35,2	85	105	19	32	64	186
	22	22								M16x1.5		17								
40	22	22	50	50	78	50	80	1/2"G	9	M16x1.5	16	17	97	40,6	98	115	19	32	71	206
	28	28								M20x1.5		22								
50	28	28	60	60	95	60	100	1/2"G	11	M20x1.5	20	22	111	48,2	116,4	140	24	38	72	225
	36	36								M27x2		28								
63	36	36	70	70	116	75	120	3/4"G	13,5	M27x2	25	28	117	55,5	134	160	29	45	82	249
	45	45								M33x2		36								
80	45	45	85	85	130	95	135	3/4"G	17,5	M33x2	32	36	134	63,1	152,5	185	36	54	91	282
	56	56								M42x2		46								
100	56	56	106	106	158	115	160	1"G	22	M42x2	32	46	162	76,5	184,8	225	37	57	108	332
	70	63								M48x2		60								
125	70	63	132	132	192	145	195	1"G	22	M48x2	32	60	174	90,2	217,1	255	37	60	121	357
	90	85								M64x3		75								

CILCOIL, S.A. - se reserva el derecho de modificar: Técnica, material, cotas y formas sin previo aviso.

CILCOIL, S.A. - reserves the rights to modify: Techniques, materials, dimensions and shapes without prior notice.

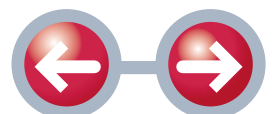



• TIPO - TYPE: DS - MP3 •

CHARNELA MACHO
CAP FIXED EYE MOUNTING

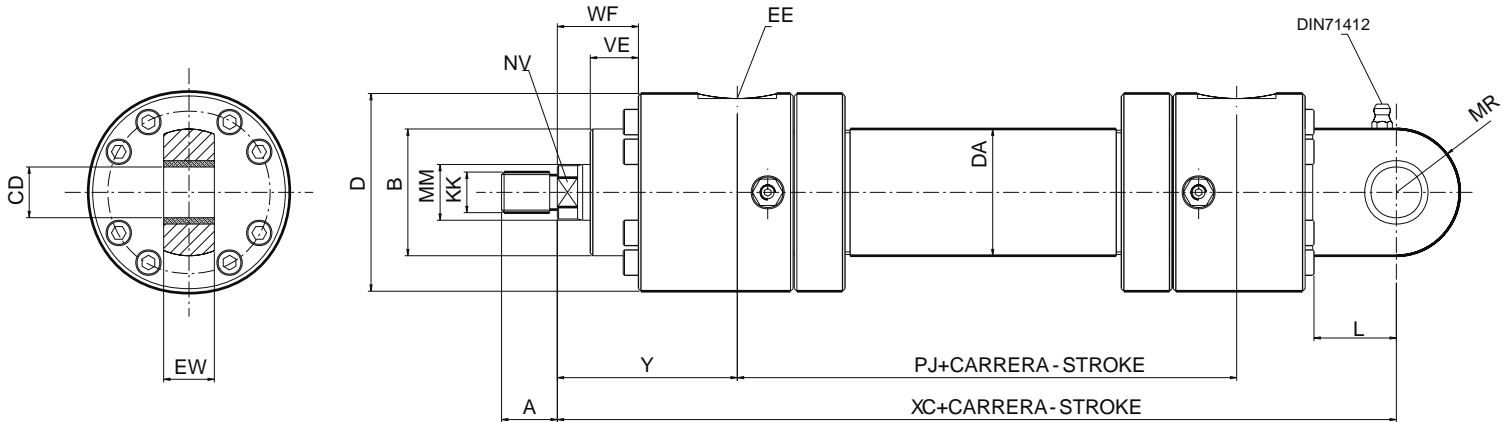

PISTON BORE	MM	A	B ₁₈	CD _{H9}	D	DA	EE	EW _{h12}	KK	L	MR	NV	PJ	UC	VE	WF	XC	Y
25	14	16	32	12	56	35	1/4"G	12	M12x1.25	23	16	12	77	90	15	28	178	58
	18	18							M14x1.5			15						
32	18	18	40	16	67	42	3/8"G	16	M14x1.5	30	20	15	89	110	19	32	206	64
	22	22							M16x1.5			17						
40	22	22	50	20	78	50	1/2"G	20	M16x1.5	33	25	17	97	125	19	32	231	71
	28	28							M20x1.5			22						
50	28	28	60	25	95	60	1/2"G	25	M20x1.5	42	32	22	111	148	24	38	257	72
	36	36							M27x2			28						
63	36	36	70	32	116	75	3/4"G	32	M27x2	53	40	28	117	170	29	45	289	82
	45	45							M33x2			36						
80	45	45	85	40	130	95	3/4"G	40	M33x2	72	50	36	134	195	36	54	332	91
	56	56							M42x2			46						
100	56	56	106	50	158	115	1"G	50	M42x2	83	63	46	162	238	37	57	395	108
	70	63							M48x2			60						
125	70	63	132	63	192	145	1"G	63	M48x2	89	71	60	174	272	37	60	428	121
	90	85							M64x3			75						
160	90	85	160	80	232	185	1 1/4"G	80	M64x3	117	90	75	191	316	41	66	505	143
	110	95							M80x3			90						
200	110	95	200	100	285	230	1 1/4"G	100	M80x3	141	112	90	224	385	45	75	615	190
	140	112							M100x3			120						
250	140	112	250	125	365	298	1 1/2"G	125	M100x3	193	160	120	290	500	64	96	773	205
	180	125							M125x4			160						
320	180	125	320	160	450	368	1 1/2"G	160	M125x4	234	200	160	358	620	71	108	930	250
	220	160							M160x4			200						

CILCOIL, S.A. - se reserva el derecho de modificar: Técnica, material, cotas y formas sin previo aviso.

CILCOIL, S.A. - reserves the rights to modify: Techniques, materials, dimensions and shapes without prior notice.

Volver
Series Fabricación

Volver
Página Principal

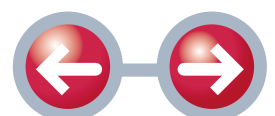



• TIPO - TYPE: FS - MT4 •
MUÑÓN INTERMEDIO
INTERMEDIATE TRUNION

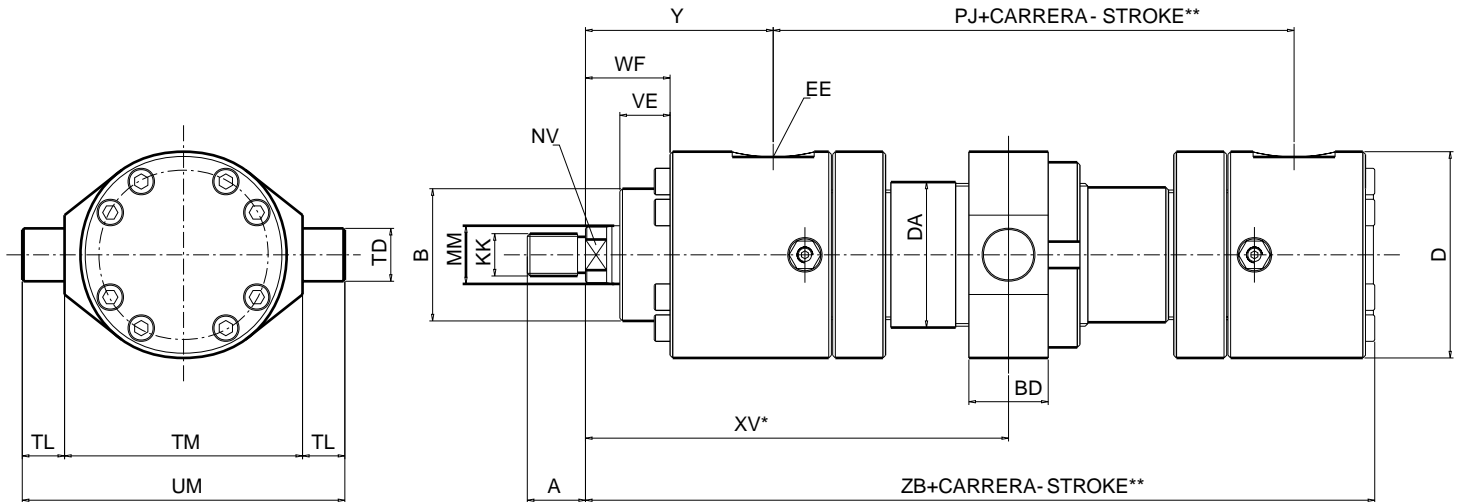

* XV máxima = (Xvmax*) + Carrera

* XV maximum = (Xvmax*) + Stroke

** La carrera mínima según cilindro es X

** The minimum stroke according cylinder is X

PISTON BORE	MM	A	B _{fr}	BD	D	DA	EE	KK	NV	PJ	TD _{fr}	TL _{js16}	TM _{h13}	UM	VE	WF	XV _{min}	XV _{max} *	Y	ZB	X
25	14	16	32	20	56	35	1/4"G	M12x1.25	12	77	12	10	63	83	15	28	107	75	58	155	40
	18	18						M14x1.5	15												
32	18	18	40	25	67	42	3/8"G	M14x1.5	15	89	16	12	75	99	19	32	120	85	64	176	40
	22	22						M16x1.5	17												
40	22	22	50	30	78	50	1/2"G	M16x1.5	17	97	20	16	90	122	19	32	135	90	71	198	45
	28	28						M20x1.5	22												
50	28	28	60	35	95	60	1/2"G	M20x1.5	22	111	25	20	105	145	24	38	145	100	72	213	50
	36	36						M27x2	28												
63	36	36	70	45	116	75	3/4"G	M27x2	28	117	32	25	120	170	29	45	165	107	82	234	55
	45	45						M33x2	36												
80	45	45	85	50	130	95	3/4"G	M33x2	36	134	40	32	135	199	36	54	180	125	91	260	60
	56	56						M42x2	46												
100	56	56	106	60	158	115	1"G	M42x2	46	162	50	40	160	240	37	57	215	150	108	310	70
	70	63						M48x2	60												
125	70	63	132	75	192	145	1"G	M48x2	60	174	63	50	195	295	37	60	240	160	121	335	80
	90	85						M64x3	75												
160	90	85	160	90	232	185	1 1/4"G	M64x3	75	191	80	63	240	366	41	66	280	177	143	380	103
	110	95						M80x3	90												
200	110	95	200	110	285	230	1 1/4"G	M80x3	90	224	100	80	295	455	45	75	350	235	190	474	115
	140	112						M100x3	120												
250	140	112	250	135	365	298	1 1/2"G	M100x3	120	290	125	100	370	570	65	96	395	297	205	580	120
	180	125						M125x4	160												
320	180	125	320	175	450	368	1 1/2"G	M125x4	160	358	160	125	470	720	71	108	495	361	250	696	134
	220	160						M160x4	200												

CILCOIL, S.A. - se reserva el derecho de modificar: Técnica, material, cotas y formas sin previo aviso.

CILCOIL, S.A. - reserves the rights to modify: Techniques, materials, dimensions and shapes without prior notice.

Volver
Series Fabricación

Volver
Página Principal

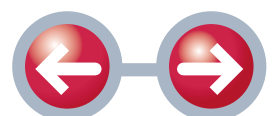



• TIPO - TYPE: ES - MS2 •

PATAS
FOOT MOUNTING

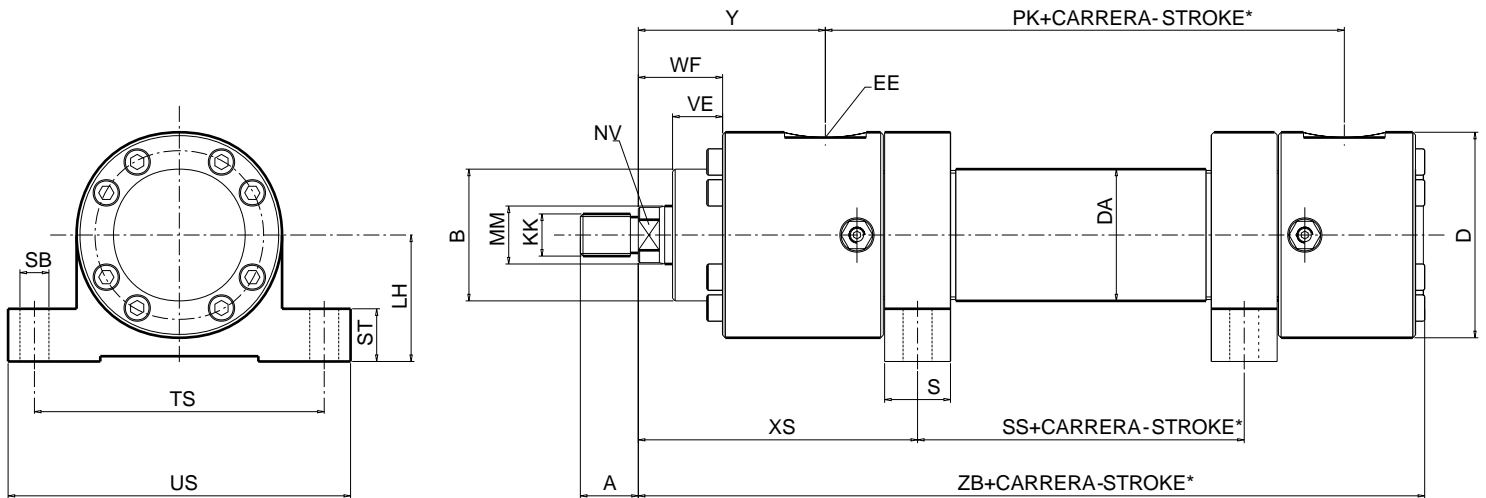

* La carrera mínima según cilindro es X

* The minimum stroke according to cylinder is X

PISTON BORE	MM	A	B _{f8}	D	DA	EE	KK	LH _{h10}	NV	PJ	S	SB _{H13}	SS	ST	TS _{js13}	US	VE	WF	XS	Y	ZB	X
25	14	16	32	56	35	1/4"G	M12x1.25	32	12	77	20	9	19	20	75	92	15	28	87	58	155	25
	18	M14x1.5					15															
32	18	18	40	67	42	3/8"G	M14x1.5	38	15	89	25	11	22	20	90	110	19	32	97,5	64	176	30
	22	M16x1.5					17															
40	22	22	50	78	50	1/2"G	M16x1.5	48	17	97	25	11	24	20	110	130	19	32	106	71	198	35
	28	M20x1.5					22															
50	28	28	60	95	60	1/2"G	M20x1.5	52	22	111	32	14	26	25	120	145	24	38	116	72	213	60
	36	M27x2					28															
63	36	36	70	116	75	3/4"G	M27x2	62	28	117	32	18	33	25	145	180	29	45	123	82	234	60
	45	M33x2					36															
80	45	45	85	130	95	3/4"G	M33x2	70	36	134	40	22	42	30	170	210	36	54	136	91	260	100
	56	M42x2					46															
100	56	56	106	158	115	1"G	M42x2	82	46	162	50	26	49	35	200	245	37	57	164	108	310	100
	70	M48x2					60															
125	70	63	132	192	145	1"G	M48x2	100	60	174	56	33	55	35	245	300	37	60	180	121	335	140
	90	M64x3					75															
160	90	85	160	232	185	1 1/4"G	M64x3	142	75	191	56	33	66	45	320	400	41	66	206	143	380	250
	110	M80x3					90															
200	110	95	200	285	230	1 1/4"G	M80x3	170	90	224	60	36	90	50	400	500	45	75	257	190	474	275
	140	M100x3					120															
250	140	112	250	365	298	1 1/2"G	M100x3	195	120	290	70	45	125	60	480	570	65	96	283	205	580	300
	180	M125x4					160															
320	180	125	320	450	368	1 1/2"G	M125x4	245	160	358	80	52	156	70	580	680	71	108	350	250	696	400
	220	M160x4					200															

CILCOIL, S.A. - se reserva el derecho de modificar: Técnica, material, cotas y formas sin previo aviso.

CILCOIL, S.A. - reserves the rights to modify: Techniques, materials, dimensions and shapes without prior notice.

Volver
Series Fabricación

Volver
Página Principal

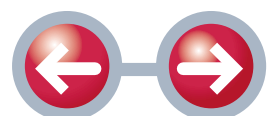



• TIPO - TYPE: GS - MP5 •
CHARNELA RÓTULA
SPHERICAL EYE MOUNTING

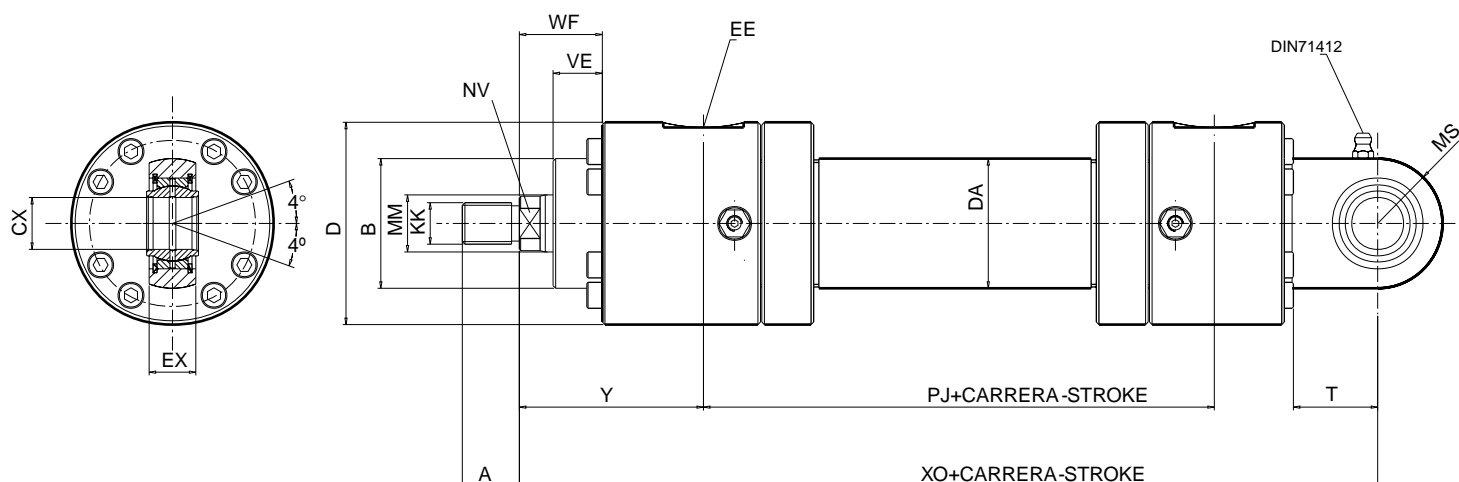

PISTON BORE	MM	A	B _{f8}	CX _{H7}	D	DA	EE	EP	EX _{H12}	KK	LT	MS	NV	PJ	VE	WF	XO	Y
25	14	16	32	12	56	35	1/4"G	10,6	12	M12x1.25	23	16	12	77	15	28	178	58
	18	18								M14x1.5			15					
32	18	18	40	16	67	42	3/8"G	14	16	M14x1.5	30	20	15	89	19	32	206	64
	22	22								M16x1.5			17					
40	22	22	50	20	78	50	1/2"G	18	20	M16x1.5	33	25	17	97	19	32	231	71
	28	28								M20x1.5			22					
50	28	28	60	25	95	60	1/2"G	22	25	M20x1.5	42	32	22	111	24	38	257	72
	36	36								M27x2			28					
63	36	36	70	32	116	75	3/4"G	27	32	M27x2	53	40	28	117	29	45	289	82
	45	45								M33x2			36					
80	45	45	85	40	130	95	3/4"G	35	40	M33x2	72	50	36	134	36	54	332	91
	56	56								M42x2			46					
100	56	56	106	50	158	115	1"G	40	50	M42x2	83	63	46	162	37	57	395	108
	70	63								M48x2			60					
125	70	63	132	63	192	145	1"G	52	63	M48x2	89	71	60	174	37	60	428	121
	90	85								M64x3			75					
160	90	85	160	80	232	185	1 1/4"G	66	80	M64x3	117	90	75	191	41	66	505	143
	110	95								M80x3			90					
200	110	95	200	100	285	230	1 1/4"G	84	100	M80x3	141	112	90	224	45	75	615	190
	140	112								M100x3			120					
250	140	112	250	125	365	298	1 1/2"G	102	125	M100x3	193	160	120	290	65	96	773	205
	180	125								M125x4			160					
320	180	125	320	160	450	368	1 1/2"G	130	160	M125x4	234	200	160	358	71	108	930	250
	220	160								M160x4			200					

CILCOIL, S.A. - se reserva el derecho de modificar: Técnica, material, cotas y formas sin previo aviso.

CILCOIL, S.A. - reserves the rights to modify: Techniques, materials, dimensions and shapes without prior notice.

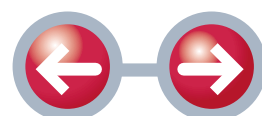



• TIPO - TYPE: AD •

BRIDA CIRCULAR - DOBLE VÁSTAGO
CIRCULAR FLANGE - DOUBLE ROD

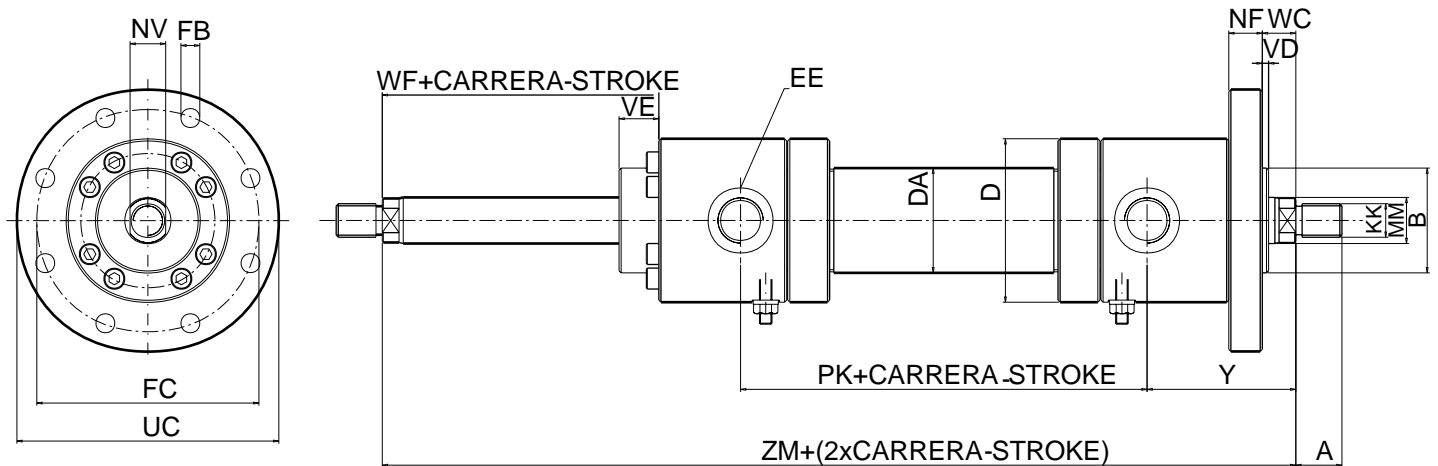

PISTON BORE	MM	A	B _{f8}	D	DA	EE	FB _{H13}	FC _{Js13}	KK	NF	NV	PK	UC	VD	VE	WC	Y	ZM
25	14	16	32	56	35	1/4"G	6,6	75	M12x1.25	12	12	77	90	3	15	16	58	193
	18	18							M14x1.5		15							
32	18	18	40	67	42	3/8"G	9	92	M14x1.5	16	15	89	110	3	19	16	64	217
	22	22							M16x1.5		17							
40	22	22	50	78	50	1/2"G	9	106	M16x1.5	16	17	94	125	3	19	16	71	236
	28	28							M20x1.5		22							
50	28	28	60	95	60	1/2"G	11	126	M20x1.5	20	22	111	148	4	24	18	72	258
	36	36							M27x2		28							
63	36	36	70	116	75	3/4"G	13,5	145	M27x2	25	28	115	170	4	29	20	82	279
	45	45							M33x2		36							
80	45	45	85	130	95	3/4"G	17,5	165	M33x2	32	36	132	195	4	36	22	91	314
	56	56							M42x2		46							
100	56	56	106	158	115	1"G	22	200	M42x2	32	46	161	238	5	37	25	108	377
	70	63							M48x2		60							
125	70	63	132	192	145	1"G	22	235	M48x2	32	60	173	272	5	37	28	121	415
	90	85							M64x3		75							
160	90	85	160	232	185	1 1/4"G	22	280	M64x3	36	75	192	316	5	41	30	143	478
	110	95							M80x3		90							
200	110	95	200	285	230	1 1/4"G	26	340	M80x3	40	90	224	385	5	45	35	190	604
	140	112							M100x3		120							
250	140	112	250	365	298	1 1/2"G	33	420	M100x3	56	120	281	500	8	64	40	205	691
	180	125							M125x4		160							
320	180	125	320	450	368	1 1/2"G	39	520	M125x4	63	160	356	620	8	71	45	250	856
	220	160							M160x4		200							

CILCOIL, S.A. - se reserva el derecho de modificar: Técnica, material, cotas y formas sin previo aviso.

CILCOIL, S.A. - reserves the rights to modify: Techniques, materials, dimensions and shapes without prior notice.

Volver
Series Fabricación

Volver
Página Principal

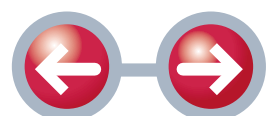



• TIPO - TYPE: ED •
PATAS - DOBLE VÁSTAGO
FOOT MOUNTING - DOUBLE ROD

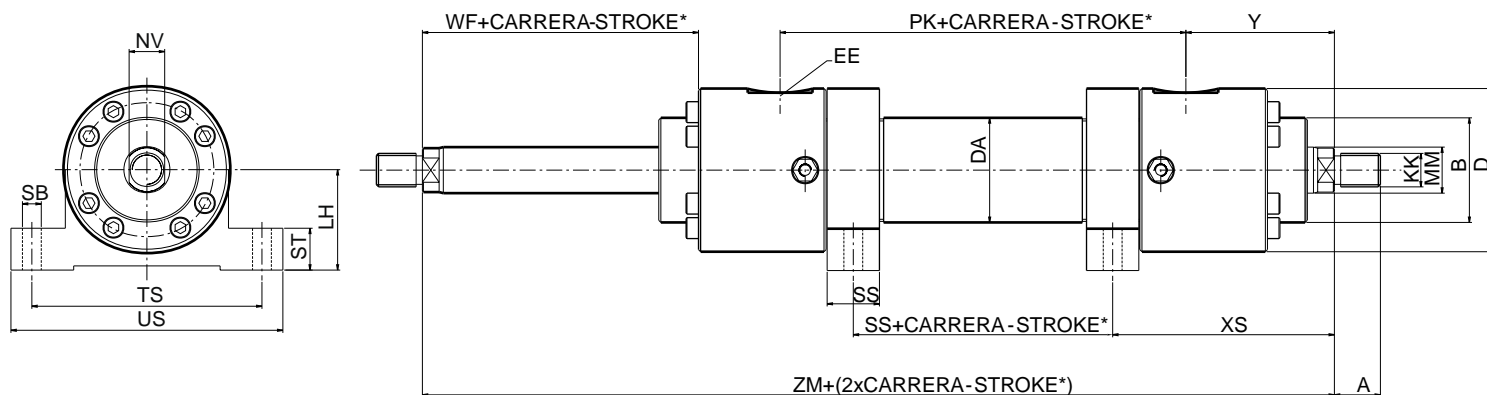

* La carrera mínima según cilindro es X

* The minimum stroke according to cylinder is X

PISTON BORE	MM	A	B _{f8}	D	DA	EE	KK	LH _{h10}	NV	PK	S	SB _{H13}	SS	ST	TS _{js13}	US	VE	WF	XS	Y	ZM	X
25	14	16	32	56	35	1/4"G	M12x1.25	32	12	77	20	9	19	20	75	92	15	28	87	58	193	25
	18	18					M14x1.5		15													
32	18	18	40	67	42	3/8"G	M14x1.5	38	15	89	25	11	22	20	90	110	19	32	97,5	64	217	30
	22	22					M16x1.5		17													
40	22	22	50	78	50	1/2"G	M16x1.5	48	17	94	25	11	24	20	110	130	19	32	106	71	236	35
	28	28					M20x1.5		22													
50	28	28	60	95	60	1/2"G	M20x1.5	52	22	114	32	14	26	25	120	145	24	38	116	72	258	60
	36	36					M27x2		28													
63	36	36	70	116	75	3/4"G	M27x2	62	28	115	32	18	33	25	145	180	29	45	123	82	279	60
	45	45					M33x2		36													
80	45	45	85	130	95	3/4"G	M33x2	70	36	132	40	22	42	30	170	210	36	54	136	91	314	100
	56	56					M42x2		46													
100	56	56	106	158	115	1"G	M42x2	82	46	161	50	26	49	35	200	245	37	57	164	108	377	100
	70	63					M48x2		60													
125	70	63	132	192	145	1"G	M48x2	100	60	173	56	33	55	35	245	300	37	60	180	121	415	140
	90	85					M64x3		75													
160	90	85	160	232	185	1 1/4"G	M64x3	142	75	192	56	33	66	45	320	400	41	66	206	143	478	250
	110	95					M80x3		90													
200	110	95	200	285	230	1 1/4"G	M80x3	170	90	224	60	36	90	50	400	500	45	75	257	190	604	275
	140	112					M100x3		120													
250	140	112	250	365	298	1 1/2"G	M100x3	195	120	281	70	45	125	60	480	570	65	96	283	205	691	300
	180	125					M125x4		160													
320	180	125	320	450	368	1 1/2"G	M125x4	245	160	356	80	52	156	70	580	680	71	108	350	250	856	400
	220	160					M160x4		200													

CILCOIL, S.A. - se reserva el derecho de modificar: Técnica, material, cotas y formas sin previo aviso.

CILCOIL, S.A. - reserves the rights to modify: Techniques, materials, dimensions and shapes without prior notice.

Volver
Series Fabricación

Volver
Página Principal

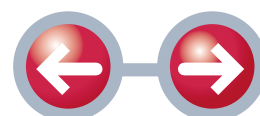



• TIPO - TYPE: FD •

MUÑÓN INTERMEDIO - DOBLE VÁSTAGO
INTERMEDIATE TRUNION - DOUBLE ROD

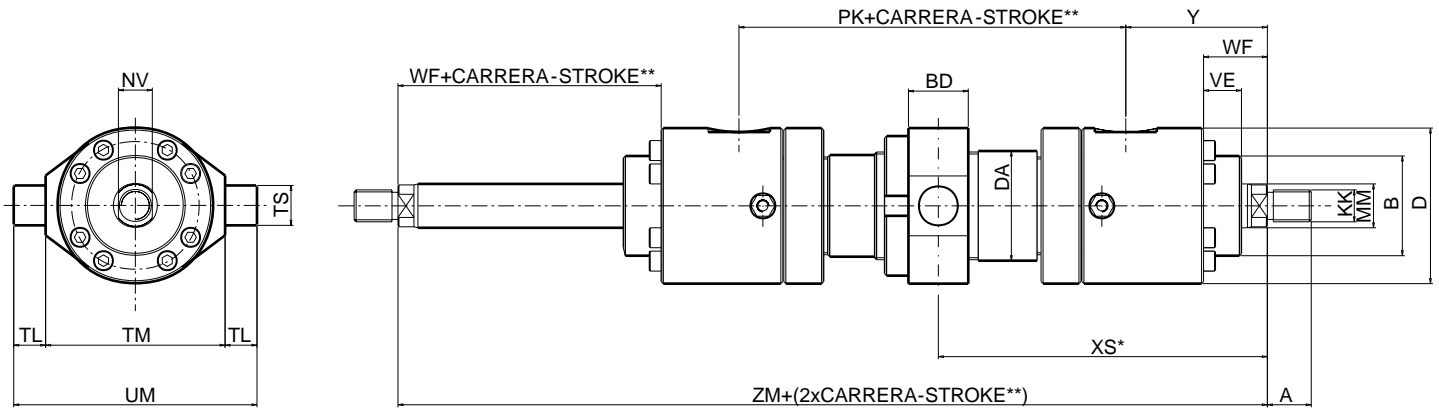

* XV máxima = (Xvmax*) + Carrera

* XV maximum = (Xvmax*) + Stroke

** La carrera mínima según cilindro es X

** The minimum stroke according cylinder is X

PISTON BORE	MM	A	B _{f8}	BD	D	DA	EE	KK	NV	PK	TD _{f8}	TL _{js16}	TM _{h13}	UM	VE	WF	XV _{min}	XV _{max} *	Y	ZM	X
25	14	16	32	20	56	35	1/4"G	M12x1.25	12	77	12	10	63	83	15	28	107	75	58	193	40
	18	18						M14x1.5	15												
32	18	18	40	25	67	42	3/8"G	M14x1.5	15	89	16	12	75	99	19	32	120	85	64	217	40
	22	22						M16x1.5	17												
40	22	22	50	30	78	50	1/2"G	M16x1.5	17	94	20	16	90	122	19	32	135	90	71	236	45
	28	28						M20x1.5	22												
50	28	28	60	35	95	60	1/2"G	M20x1.5	22	114	25	20	105	145	24	38	145	100	72	258	50
	36	36						M27x2	28												
63	36	36	70	45	116	75	3/4"G	M27x2	28	115	32	25	120	170	29	45	165	107	82	279	55
	45	45						M33x2	36												
80	45	45	85	50	130	95	3/4"G	M33x2	36	132	40	32	135	199	36	54	180	125	91	314	60
	56	56						M42x2	46												
100	56	56	106	60	158	115	1"G	M42x2	46	161	50	40	160	240	37	57	215	150	108	377	70
	70	63						M48x2	60												
125	70	63	132	75	192	145	1"G	M48x2	60	173	63	50	195	295	37	60	240	160	121	415	80
	90	85						M64x3	75												
160	90	85	160	90	232	185	1 1/4"G	M64x3	75	192	80	63	240	366	41	66	280	177	143	478	103
	110	95						M80x3	90												
200	110	95	200	110	285	230	1 1/4"G	M80x3	90	224	100	80	295	455	45	75	350	235	190	604	115
	140	112						M100x3	120												
250	140	112	250	135	365	298	1 1/2"G	M100x3	120	281	125	100	370	570	65	96	395	297	205	691	120
	180	125						M125x4	160												
320	180	125	320	175	450	368	1 1/2"G	M125x4	160	356	160	125	470	720	71	108	495	361	250	856	134
	220	160						M160x4	200												

CILCOIL, S.A. - se reserva el derecho de modificar: Técnica, material, cotas y formas sin previo aviso.

CILCOIL, S.A. - reserves the rights to modify: Techniques, materials, dimensions and shapes without prior notice.

Volver
Series Fabricación

Volver
Página Principal

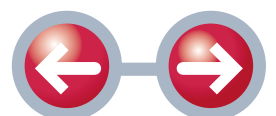



• TIPO - TYPE: ND •

BRIDA RECTANGULAR - DOBLE VÁSTAGO
RECTANGULAR FLANGE - DOUBLE ROD

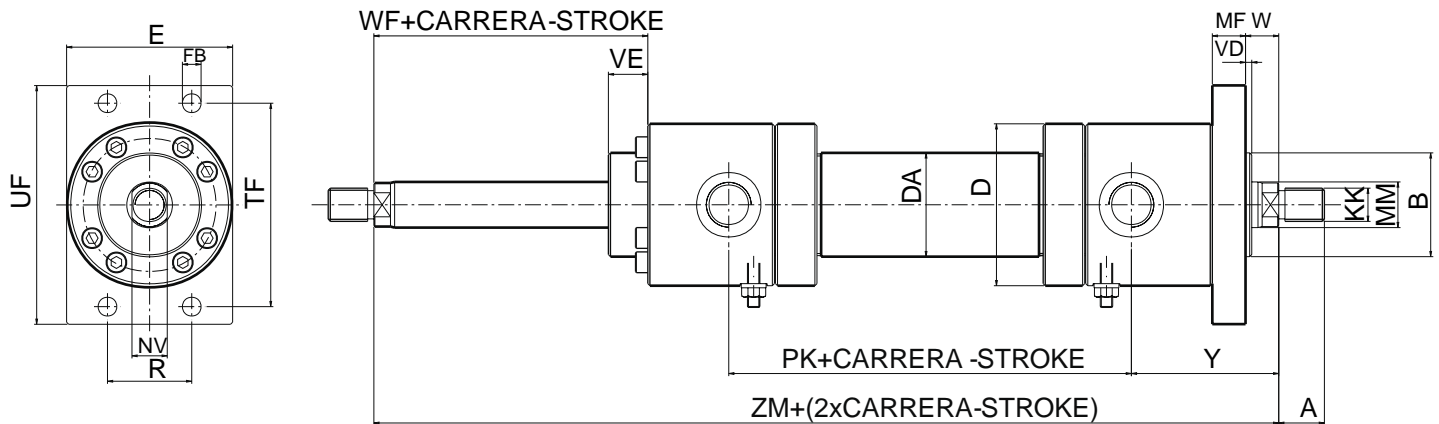

MM	A	B _{f8}	D	DA	E	EE	FB _{H13}	KK	MF	NV	PK	R _{js13}	TF _{js13}	UF	VE	VD	W	Y	ZM
14	16	32	56	35	60	1/4"G	6,6	M12x1.25	12	12	77	28,7	69,2	85	15	3	16	58	193
18	18							M14x1.5		15									
18	18	40	67	42	70	3/8"G	9	M14x1.5	16	15	89	35,2	85	105	19	3	16	64	217
22	22							M16x1.5		17									
22	22	50	78	50	80	1/2"G	9	M16x1.5	16	17	94	40,6	98	115	19	3	16	71	236
28	28							M20x1.5		22									
28	28	60	95	60	100	1/2"G	11	M20x1.5	20	22	114	48,2	116,4	140	24	4	18	72	258
36	36							M27x2		28									
36	36	70	116	75	120	3/4"G	13,5	M27x2	25	28	115	55,5	134	160	29	4	20	82	279
45	45							M33x2		36									
45	45	85	130	95	135	3/4"G	17,5	M33x2	32	36	132	63,1	152,5	185	36	4	22	91	314
56	56							M42x2		46									
56	56	106	158	115	160	1"G	22	M42x2	32	46	161	76,5	184,8	225	37	5	25	108	377
70	63							M48x2		60									
70	63	132	192	145	195	1"G	22	M48x2	32	60	173	90,2	217,1	255	37	5	28	121	415
90	85							M64x3		75									

CILCOIL, S.A. - se reserva el derecho de modificar: Técnica, material, cotas y formas sin previo aviso.

CILCOIL, S.A. - reserves the rights to modify: Techniques, materials, dimensions and shapes without prior notice.

Volver
Series Fabricación

Volver
Página Principal

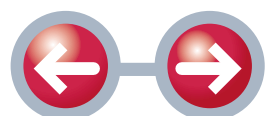



• CONEXIONES - CONECTIONS •

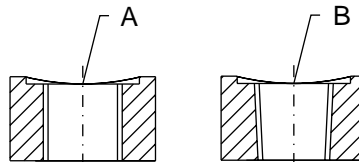

PISTON BORE	D	ESTANDAR		SOBRE DEMANDA / ON REQUEST		
		G GAS / BSP ISO 228/1	M METRICA METRIC	N NPT	S ISO DIS 6162.2	
		A	A	B	EE	
25	56	1/4"	12x1,5	1/4"	-	
32	67	3/8"	16x1,5	3/8"	-	
40	78	1/2"	22x1,5	1/2"	-	
50	95	1/2"	22x1,5	1/2"	-	
63	116	3/4"	27x2	3/4"	13	
80	130	3/4"	27x2	3/4"	13	
100	158	1"	33x2	1"	19	
125	192	1"	33x2	1"	19	
160	232	1 1/4"	42x2	1 1/4"	25	
200	285	1 1/4"	42x2	1 1/4"	25	
250	365	1 1/2"	48x2	1 1/2"	32	
320	450	1 1/2"	48x2	1 1/2"	32	

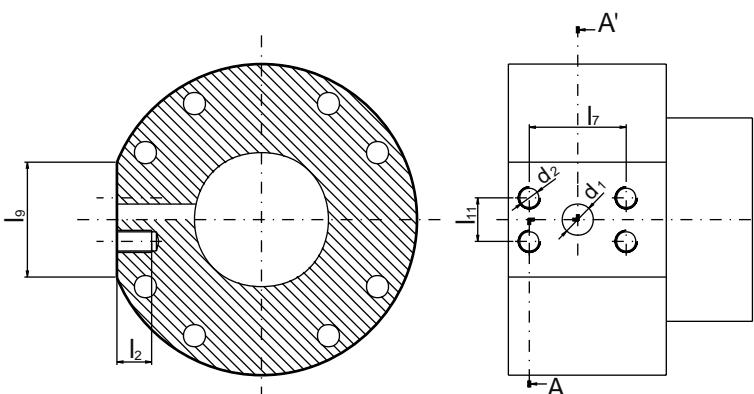

ISO/DIS6162.2

DN	d ₁	d ₂	l ₁ \geq 0,25	l ₇ \geq 0,25	l ₉	l ₂
13	13	M8x1,25	18,2	40,5	48	14,5
19	19	M10x1,50	23,8	50,8	60	16,5
25	25	M12x1,75	27,8	57,2	70	21,5
32	32	M12x1,75	31,8	66,6	78	18,5
38	38	M16x2	36,5	79,3	95	25,5
51	51	M20x2,50	44,5	96,8	114	33,5

CILCOIL, S.A. - se reserva el derecho de modificar: Técnica, material, cotas y formas sin previo aviso.

CILCOIL, S.A. - reserves the rights to modify: Techniques, materials, dimensions and shapes without prior notice.

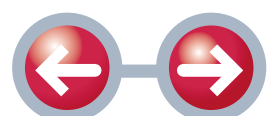



• TOLERANCIAS Y PESOS - TOLERANCES AND WEIGHT •

Tolerancias Dimensiones según fijación (ISO8135) / Mounting Dimensions (ISO8135)

Dimensiones Dimensions	Y	PJ*	WF	ZJ*	WC	W	XS	SS*	XC*	XO*	XV	ZP/ZF*
Tipo de Fijación Mounting Type	Basico Basic	Basico Basic	Basico Basic	Basico Basic	MF3	MF1	MS2	MS2	MP3	MP5	MT4	MF2 MF4
Carrera / Stroke	TOLERANCIAS / TOLERANCES											
≤ 1250	± 2	± 1,5	± 2	± 1,5	± 2	± 2	± 2	± 1,5	± 1,5	± 1,5	± 2	± 1,5
[1250 , 3150]	± 4	± 3	± 4	± 3	± 4	± 4	± 4	± 3	± 3	± 3	± 4	± 3
[3150 , 8000]	± 8	± 5	± 8	± 5	± 8	± 8	± 8	± 5	± 5	± 5	± 8	± 5

* Carrera incluida
* Stroke length included

* Valores en milímetros
* Values in millimeters

* Valores en milímetros
* Values in millimeters

CARRERA / STROKE	TOLERANCIA
≤ 1250	+ 2 0
[1250 , 3150]	± 4 0
[3150 , 8000]	± 8 0

Tabla de pesos (kg) / Weight table (kg)

PISTON BORE	MM	N - MF1	P - MF2	A - MF3	B - MF4	G - MP5 D- MP3	E - MS2	F - MT4	Suplemento 100 mm Carrera Additional per 100 mm. Stroke
25	14	3,2	3,2	3,3	3,3	3	3,6	3,2	0,33
	18	3,3	3,3	3,4	3,4	3,1	3,7	3,3	0,41
32	18	4,5	4,5	4,8	4,8	4,1	6,2	4,5	0,55
	22	4,7	4,7	5	5	4,3	6,4	4,7	0,65
40	22	7,4	7,4	7,4	7,4	6,6	8,6	7,5	0,85
	28	7,6	7,6	7,6	7,6	6,8	8,8	7,7	1,04
50	28	9,7	9,7	10,2	10,2	8,6	12,1	10,2	1,18
	36	9,8	9,8	10,3	10,3	8,7	12,2	10,3	1,48
63	36	16,5	16,5	18,1	18,1	14,7	20,2	17,1	1,8
	45	16,9	16,9	18,5	18,5	15,1	20,6	17,5	2,3
80	45	24,1	24,1	25	25	21,5	30,9	25,5	2,9
	56	24,6	24,6	25,5	25,5	22	31,4	26	3,5
100	56	42,5	42,5	45,7	45,7	39,6	54,7	46,5	4,6
	70	44,5	44,5	46,7	46,7	40,6	55,7	47,5	5,7
125	70	66,5	66,5	67,8	67,8	63	85,4	75,2	7,2
	90	67,7	67,7	69	69	64,2	86,6	76,4	9,2
160	90	-	-	119	119	114	144	125	11,5
	110	-	-	122	122	117	147	128	13,9
200	110	-	-	209	209	205	255	231	15,3
	140	-	-	211	211	207	257	233	19,9

CILCOIL, S.A. - se reserva el derecho de modificar: Técnica, material, cotas y formas sin previo aviso.

CILCOIL, S.A. - reserves the rights to modify: Techniques, materials, dimensions and shapes without prior notice.

Volver
Series Fabricación

Volver
Página Principal

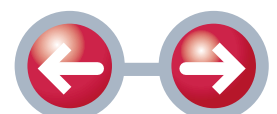



• CHARNELA HEMBRA FORMA B (ISO 8132) •

• CLEVIS BRACKET FORM B (ISO 8132) •

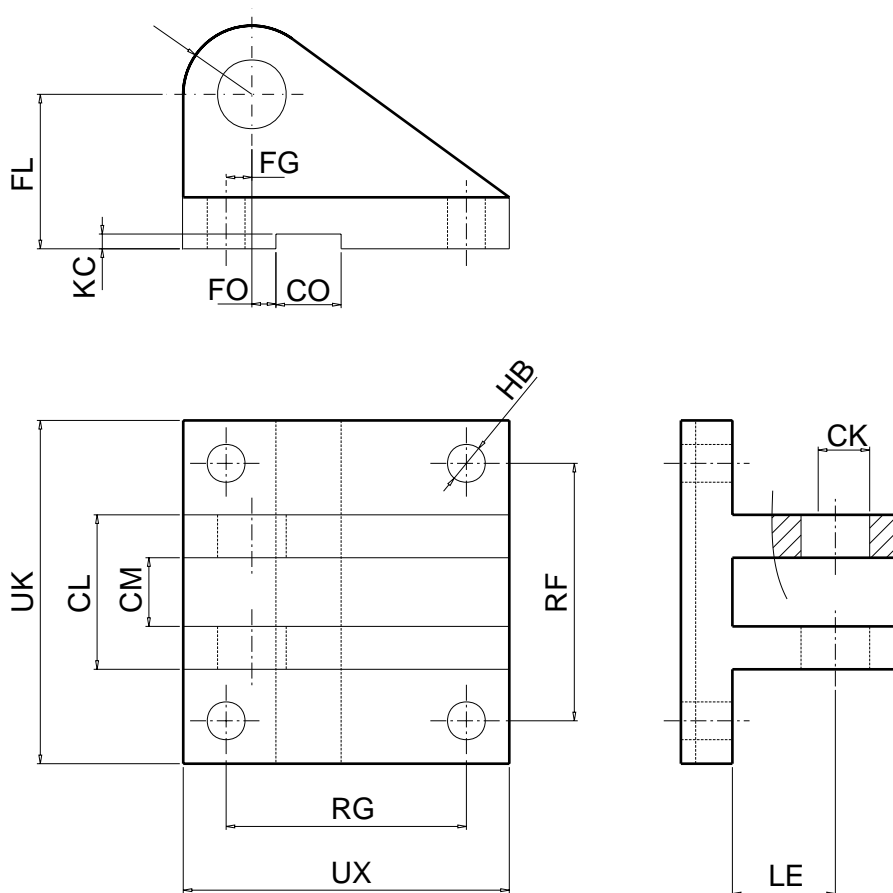

CODIGO	CK _{H9}	CL _{h16}	CM _{A12}	FL _{Js12}	HB _{H13}	CO _{N9}	LE	MR	RG _{Js14}	RF _{Js14}	UX	UK	FG _{Js14}	KC ^{+0,3} ₀	FO _{Js14}
50R025	12	28	12	34	9	10	22	12	45	52	65	72	2	3,3	10
50R032	16	36	16	40	11	16	27	16	55	65	80	90	3,5	4,3	10
50R040	20	45	20	45	11	16	30	20	70	75	95	100	7,5	4,3	10
50R050	25	56	25	55	13,5	25	37	25	85	90	115	120	10	5,4	10
50R063	32	70	32	65	17,5	25	43	32	110	110	145	145	14,5	5,4	6
50R080	40	90	40	76	22	36	52	40	125	140	170	185	17,5	8,4	6
50R100	50	110	50	95	26	36	65	50	150	165	200	215	25	8,4	-
50R125	63	140	63	112	33	50	75	63	170	210	230	270	33	11,4	-
50R160	80	170	80	140	39	50	95	80	210	250	280	320	45	11,4	-

CILCOIL, S.A. - se reserva el derecho de modificar: Técnica, material, cotas y formas sin previo aviso.

CILCOIL, S.A. - reserves the rights to modify: Techniques, materials, dimensions and shapes without prior notice.

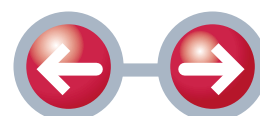



• **ARRASTRADOR RÓTULA (ISO 6982)** •

• ROD END SPHERICAL EYES (ISO 6982) •

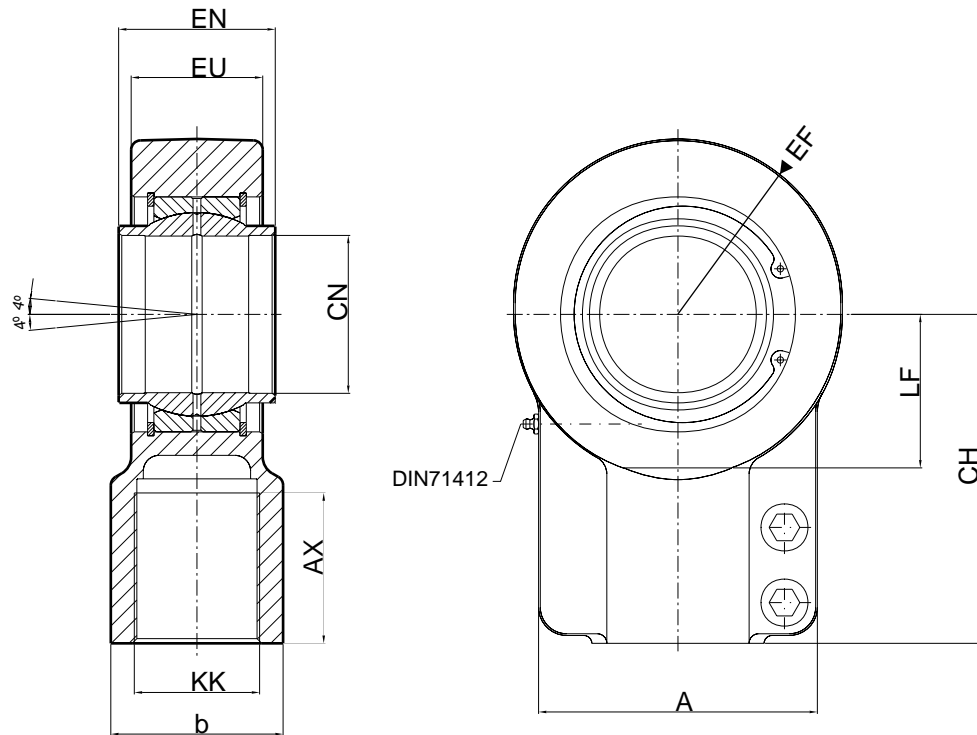

CODIGO	CN _{H7}	EN _{H12}	KK	AX	CH	LF	EF	b	EU	A
51R025	12	12	M12x1,25	17	38	14	16	16	10,5	32
51R032	16	16	M14x1,5	19	44	18	20	21	13	40
51R040	20	20	M16x1,5	23	52	22	25	25	17	47
51R050	25	25	M20x1,5	29	65	27	32	30	21	54
51R063	32	32	M27x2	37	80	32	40	38	27	66
51R080	40	40	M33x2	46	97	41	50	47	32	80
51R100	50	50	M42x2	57	120	50	63	58	40	96
51R125	63	63	M48x2	64	140	62	71	70	52	114
51R160	80	80	M64x3	86	180	78	90	90	66	148
51R200	100	100	M80x3	96	210	98	112	110	84	178
51R250	125	125	M100x3	113	260	120	160	135	103	200
51R320	160	160	M125x4	126	310	150	200	165	130	250

CILCOIL, S.A. - se reserva el derecho de modificar: Técnica, material, cotas y formas sin previo aviso.

CILCOIL, S.A. - reserves the rights to modify: Techniques, materials, dimensions and shapes without prior notice.

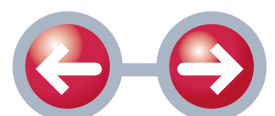



• **ARRASTRADOR MACHO (ISO 6981)** •

• ROD END PLAIN EYES (ISO 6981) •

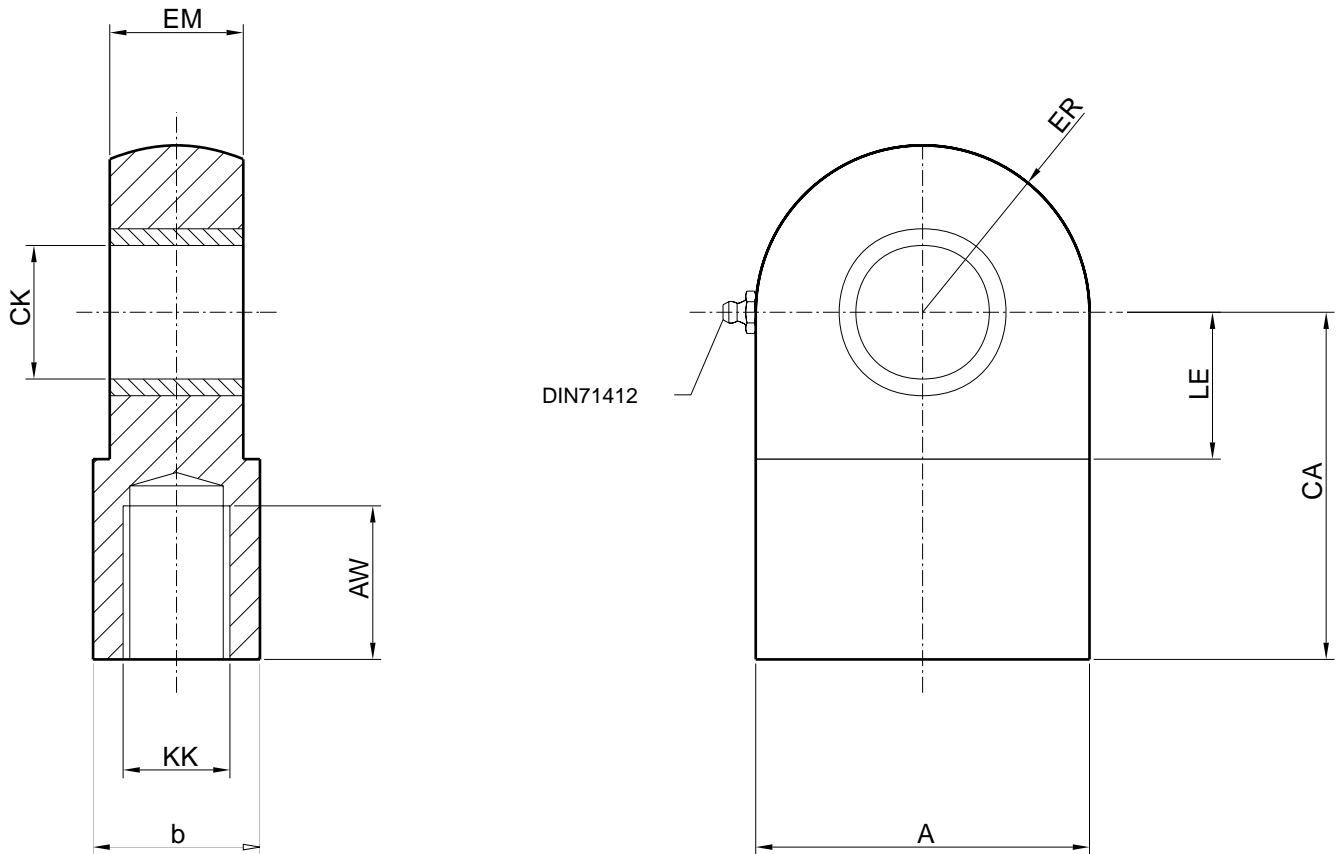

CODIGO	CK _{H9}	EM _{h12}	KK	AW	CA	LE	ER	b	A
52R025	12	12	M12x1,25	17	38	14	16	16	32
52R032	16	16	M14x1,5	19	44	18	20	20	40
52R040	20	20	M16x1,5	23	52	22	25	25	50
52R050	25	25	M20x1,5	29	65	27	32	32	64
52R063	32	32	M27x2	37	80	32	40	40	80
52R080	40	40	M33x2	46	97	41	50	50	100
52R100	50	50	M42x2	57	120	50	63	63	126
52R125	63	63	M48x2	64	140	62	71	71	142
52R160	80	80	M64x3	86	180	78	90	90	180
52R200	100	100	M80x3	96	210	98	112	112	224
52R250	125	125	M100x3	113	260	120	160	160	320
52R320	160	160	M125x4	126	310	150	200	200	400

CILCOIL, S.A. - se reserva el derecho de modificar: Técnica, material, cotas y formas sin previo aviso.

CILCOIL, S.A. - reserves the rights to modify: Techniques, materials, dimensions and shapes without prior notice.

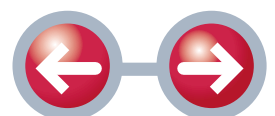



• HORQUILLA (ISO 8132) •

• ROD CLEVIS (ISO 8132) •

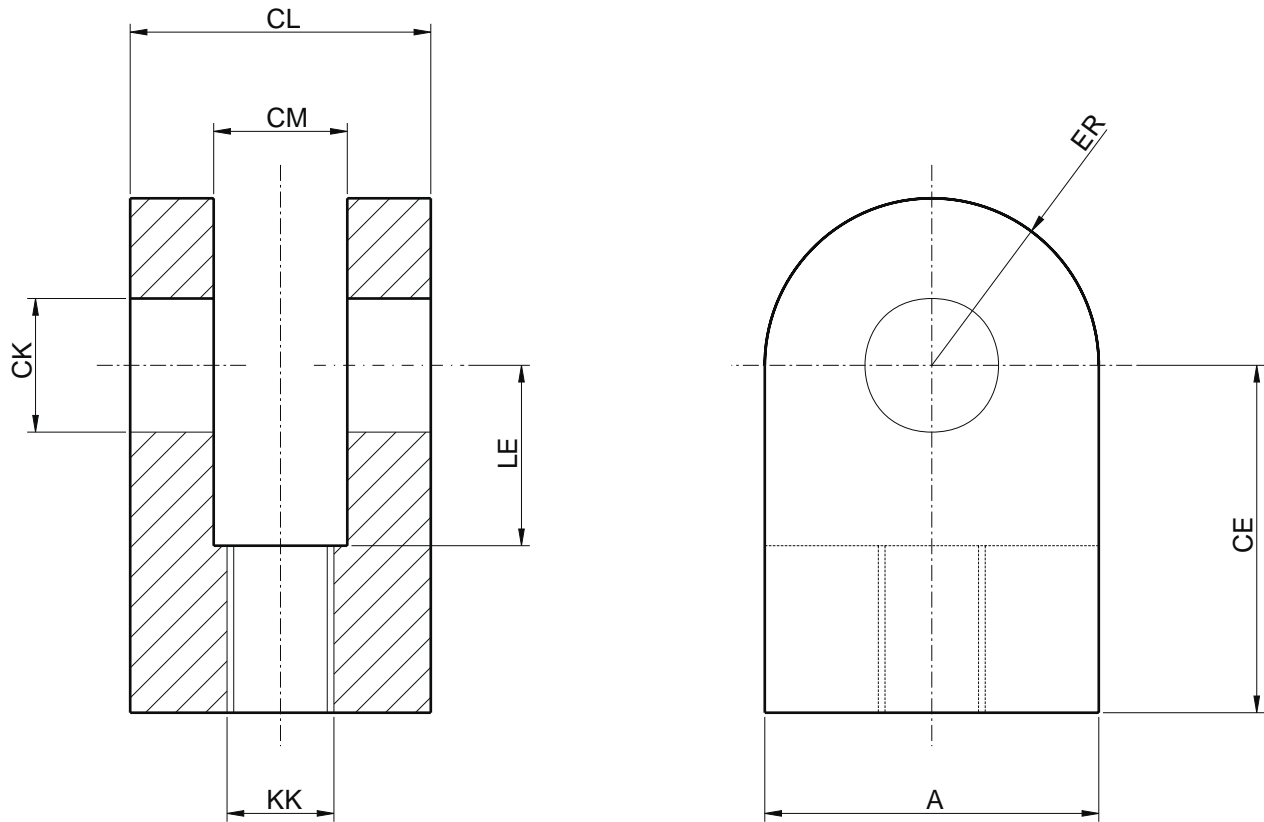

CODIGO	CK_{H9}	CL_{h16}	CM_{A12}	CE_{Js12}	KK	LE	ER	A
53R025	12	28	12	38	M12x1,25	18	16	32
53R032	16	36	16	44	M14x1,5	22	20	40
53R040	20	45	20	52	M16x1,5	27	25	50
53R050	25	56	25	65	M20x1,5	34	32	64
53R063	32	70	32	80	M27x2	42	40	80
53R080	40	90	40	97	M33x2	52	50	100
53R100	50	110	50	120	M42x2	64	63	126
53R125	63	140	63	140	M48x2	75	71	142
53R160	80	170	80	180	M64x3	94	90	180

CILCOIL, S.A. - se reserva el derecho de modificar: Técnica, material, cotas y formas sin previo aviso.

CILCOIL, S.A. - reserves the rights to modify: Techniques, materials, dimensions and shapes without prior notice.

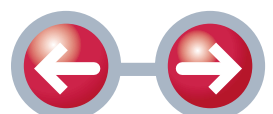



• BRIDA VÁSTAGO (ISO 8132) •

• ROD FLANGES (ISO 8132) •

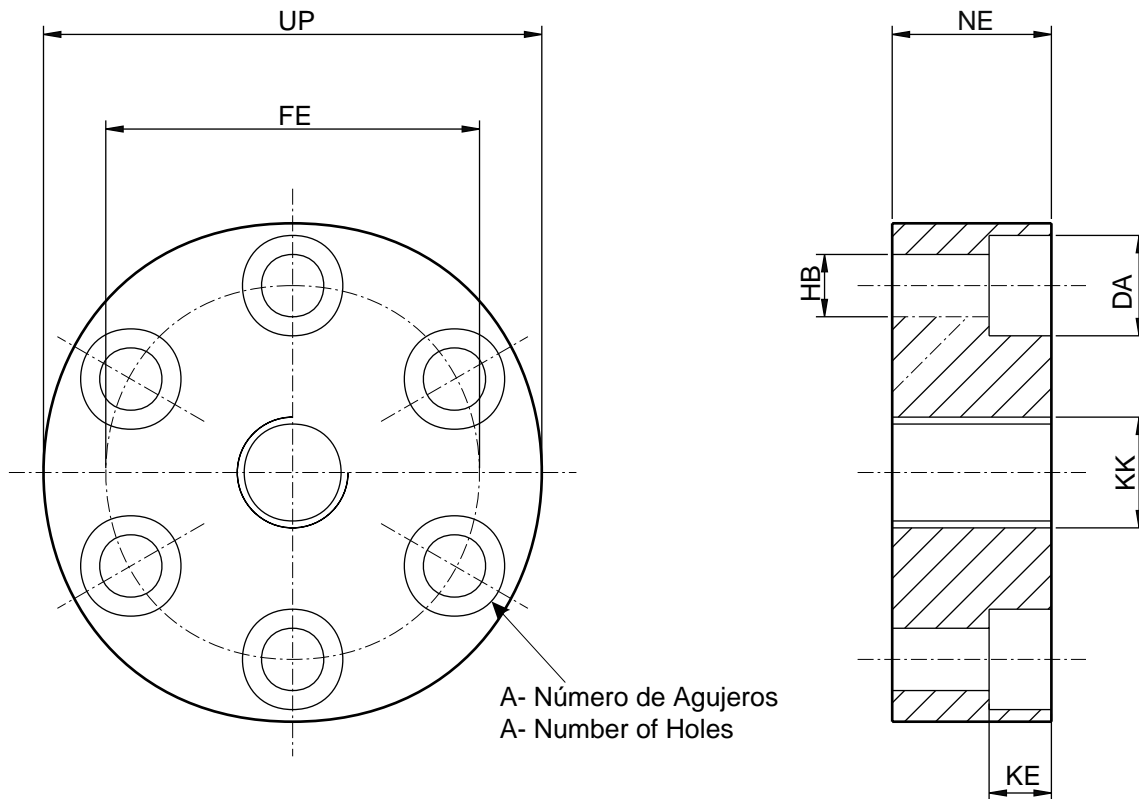

CODIGO	KK	FE_{Js13}	A	HB_{H13}	NE_{h13}	UP	DA_{H13}	KE^{+0,4}₀
54R025	M12x1,25	40	4	6,6	17	56	11	6,8
54R032	M14x1,5	45	4	9	19	63	14,5	9
54R040	M16x1,5	54	6	9	23	72	14,5	9
54R050	M20x1,5	63	6	9	29	82	14,5	9
54R063	M27x2	78	6	11	37	100	17,5	11
54R080	M33x2	95	8	13,5	46	120	20	13
54R100	M42x2	120	8	17,5	57	150	26	17,5
54R125	M48x2	150	8	22	64	190	33	21,5
54R160	M64x3	180	8	26	86	230	39	25,5

CILCOIL, S.A. - se reserva el derecho de modificar: Técnica, material, cotas y formas sin previo aviso.

CILCOIL, S.A. - reserves the rights to modify: Techniques, materials, dimensions and shapes without prior notice.

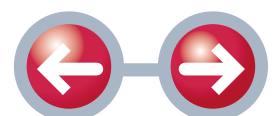



• CHARNELA HEMBRA FORMA A (ISO 8132) •
• CLEVIS BRACKET FORM A (ISO 8132) •

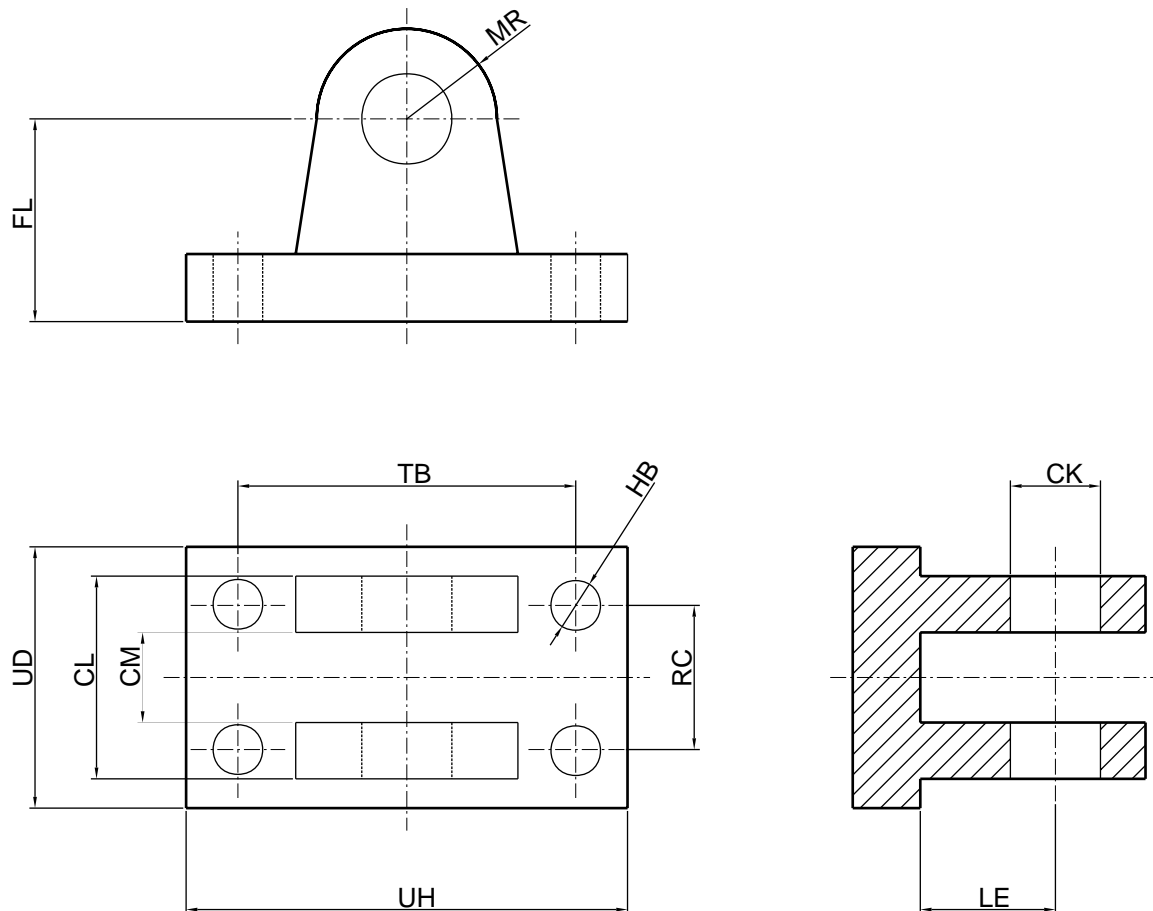

CODIGO	CK _{H9}	CL _{h16}	CM _{A12}	FL _{Js12}	HB _{H13}	LE	MR	RC _{Js14}	TB _{Js14}	UD	UH
55R025	12	28	12	34	9	22	12	20	50	40	70
55R032	16	36	16	40	11	27	16	26	65	50	90
55R040	20	45	20	45	11	30	20	32	75	58	98
55R050	25	56	25	55	13,5	37	25	40	85	70	113
55R063	32	70	32	65	17,5	43	32	50	110	85	143
55R080	40	90	40	76	22	52	40	65	130	108	170
55R100	50	110	50	95	26	65	50	80	170	130	220
55R125	63	140	63	112	33	75	63	100	210	160	270
55R160	80	170	80	140	39	95	80	125	250	210	320

CILCOIL, S.A. - se reserva el derecho de modificar: Técnica, material, cotas y formas sin previo aviso.

CILCOIL, S.A. - reserves the rights to modify: Techniques, materials, dimensions and shapes without prior notice.

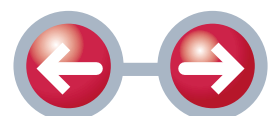



• SOPORTE MUÑÓN (ISO 8132) •

• TRUNION BRACKET (ISO 8132) •

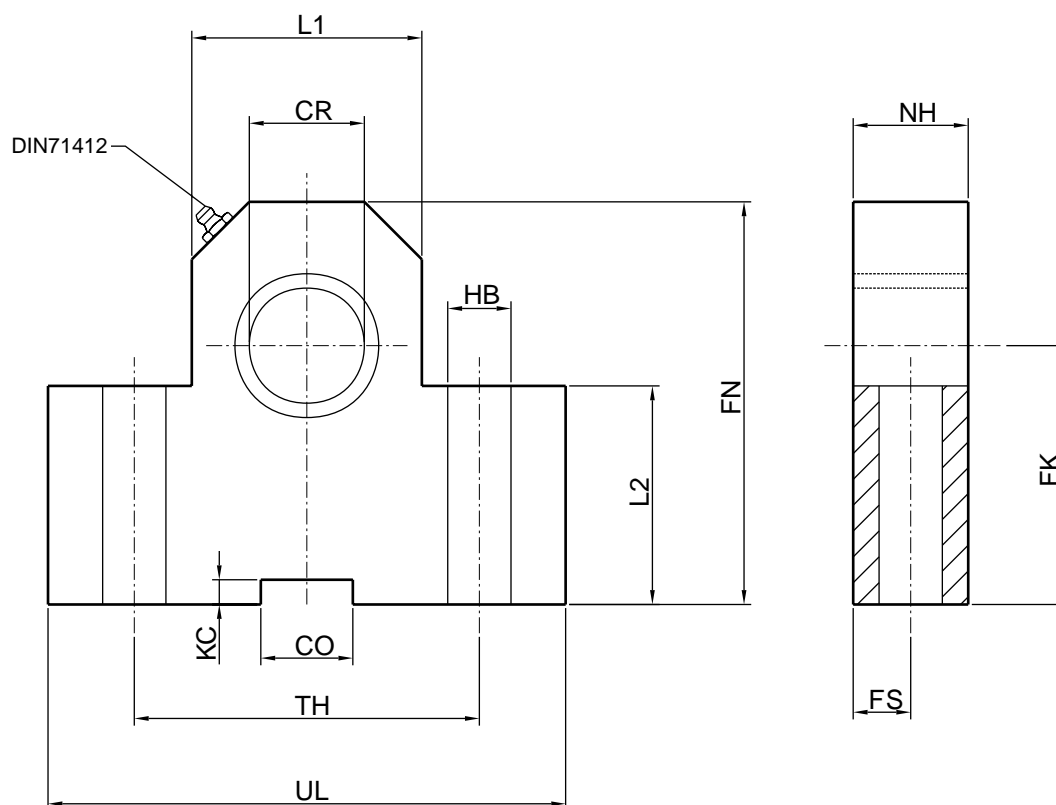

CODIGO	CR _{H7}	FK _{Js12}	FN	HB _{H13}	NH	TH _{Js14}	UL	L1	L2	CO _{N9}	KC ^{+0,3} ₀	FS _{Js14}
56R025	12	34	50	9	16	40	63	25	25	10	3,3	8
56R032	16	40	60	11	20	50	80	30	30	16	4,3	10
56R040	20	45	70	11	20	60	90	40	38	16	4,3	10
56R050	25	55	80	13,5	24	80	110	56	45	25	5,4	12
56R063	32	65	100	17,5	30	110	150	70	52	25	5,4	15
56R080	40	76	120	22	32	125	170	88	60	36	8,4	16
56R100	50	95	140	26	40	160	210	100	75	36	8,4	20
56R125	63	112	180	33	50	200	265	130	85	50	11,4	25
56R160	80	140	220	39	62	250	325	160	112	50	11,4	31

CILCOIL, S.A. - se reserva el derecho de modificar: Técnica, material, cotas y formas sin previo aviso.

CILCOIL, S.A. - reserves the rights to modify: Techniques, materials, dimensions and shapes without prior notice.

Volver
Series Fabricación

Volver
Página Principal

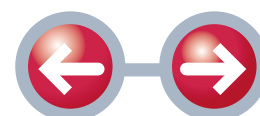



- PERNO (ISO 8132) •
- PIVOT PIN (ISO 8132) •

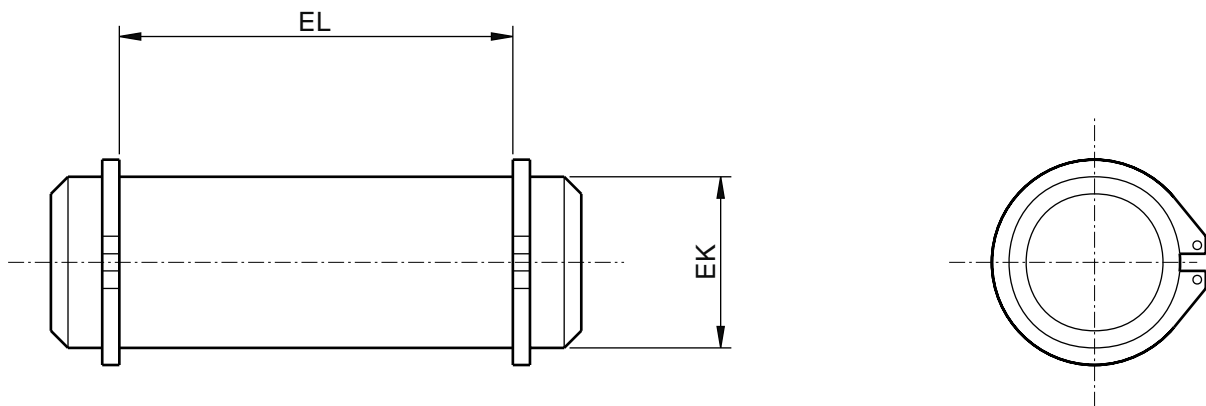

CODIGO	EK_{f8}	EL_{H16}
57R025	12	29
57R032	16	37
57R040	20	46
57R050	25	57
57R063	32	72
57R080	40	92
57R100	50	112
57R125	63	142
57R160	80	172

CILCOIL, S.A. - se reserva el derecho de modificar: Técnica, material, cotas y formas sin previo aviso.

CILCOIL, S.A. - reserves the rights to modify: Techniques, materials, dimensions and shapes without prior notice.

Volver
Series Fabricación

Volver
Página Principal

