

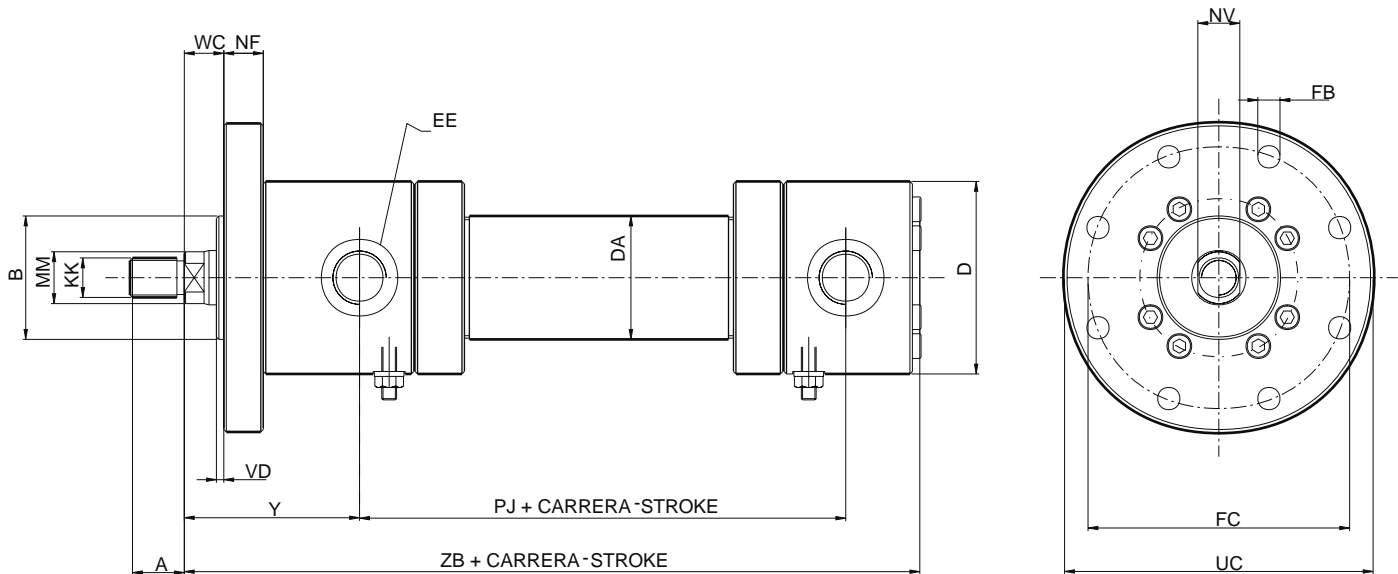

• TIPO - TYPE: AS - MF3 •
BRIDA DELANTERA CIRCULAR
HEAD CIRCULAR FLANGE MOUNTING



PISTON BORE	MM	A	B _{f8}	D	DA	EE	FB _{H13}	FC _{Js13}	KK	NF	NV	PJ	UC	VD	WC	Y	ZB
25	14	16	32	56	35	1/4"G	6,6	75	M12x1.25	12	12	77	90	3	16	58	155
	18	18							M14x1.5		15						
32	18	18	40	67	42	3/8"G	9	92	M14x1.5	16	15	89	110	3	16	64	176
	22	22							M16x1.5		17						
40	22	22	50	78	50	1/2"G	9	106	M16x1.5	16	17	97	125	3	16	71	198
	28	28							M20x1.5		22						
50	28	28	60	95	60	1/2"G	11	126	M20x1.5	20	22	111	148	4	18	72	213
	36	36							M27x2		28						
63	36	36	70	116	75	3/4"G	13,5	145	M27x2	25	28	117	170	4	20	82	234
	45	45							M33x2		36						
80	45	45	85	130	95	3/4"G	17,5	165	M33x2	32	36	134	195	4	22	91	260
	56	56							M42x2		46						
100	56	56	106	158	115	1"G	22	200	M42x2	32	46	162	238	5	25	108	310
	70	63							M48x2		60						
125	70	63	132	192	145	1"G	22	235	M48x2	32	60	174	272	5	28	121	335
	90	85							M64x3		75						
160	90	85	160	232	185	1 1/4"G	22	280	M64x3	36	75	191	316	5	30	143	380
	110	95							M80x3		90						
200	110	95	200	285	230	1 1/4"G	26	340	M80x3	40	90	224	385	5	35	190	474
	140	112							M100x3		120						
250	140	112	250	365	298	1 1/2"G	33	420	M100x3	56	120	290	500	8	40	205	580
	180	125							M125x4		160						
320	180	125	320	450	368	1 1/2"G	39	520	M125x4	63	160	358	620	8	45	250	696
	220	160							M160x4		200						

CILCOIL, S.A. - se reserva el derecho de modificar: Técnica, material, cotas y formas sin previo aviso.

CILCOIL, S.A. - reserves the rights to modify: Techniques, materials, dimensions and shapes without prior notice.

Volver
Series Fabricación

Volver
Página Principal

