

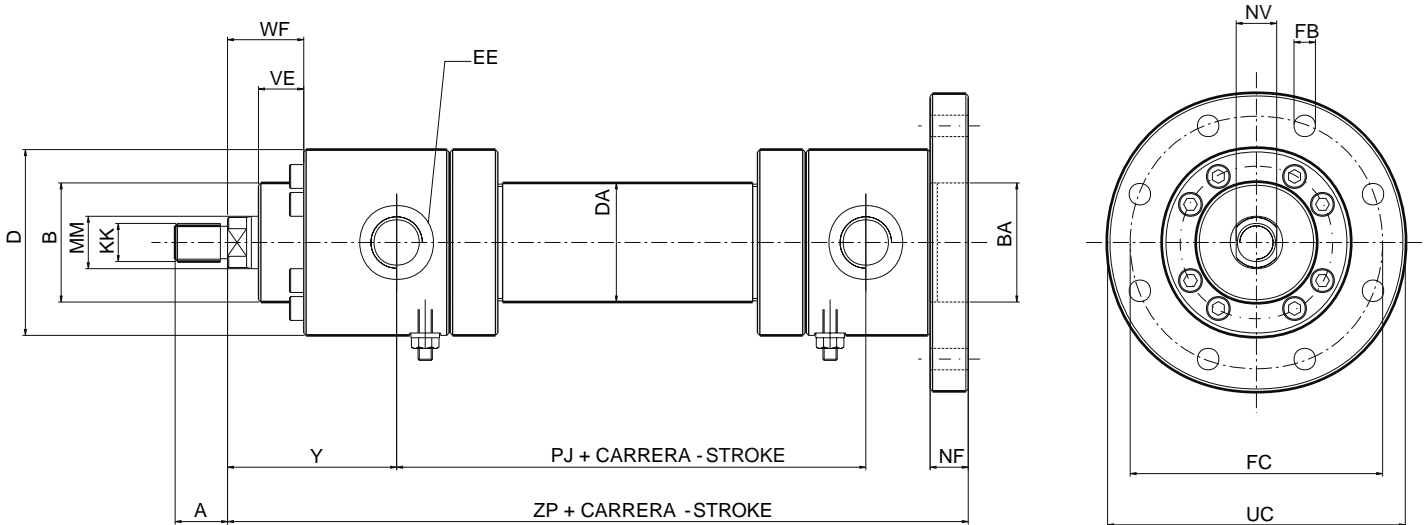

• TIPO - TYPE: BS - MF4 •  
BRIDA TRASERA CIRCULAR  
CAP CIRCULAR FLANGE MOUNTING



PISTON BORE	MM	A	B <sub>f8</sub>	BA <sub>H8</sub>	D	DA	EE	FB <sub>H13</sub>	FC <sub>Js13</sub>	KK	NF	NV	PJ	UC	VE	WF	Y	ZP
25	14	16	32	32	56	35	1/4"G	6,6	75	M12x1.25	12	12	77	90	15	28	58	162
	18	18								M14x1.5		15						
32	18	18	40	40	67	42	3/8"G	9	92	M14x1.5	16	15	89	110	19	32	64	186
	22	22								M16x1.5		17						
40	22	22	50	50	78	50	1/2"G	9	106	M16x1.5	16	17	97	125	19	32	71	206
	28	28								M20x1.5		22						
50	28	28	60	60	95	60	1/2"G	11	126	M20x1.5	20	22	111	148	24	38	72	225
	36	36								M27x2		28						
63	36	36	70	70	116	75	3/4"G	13,5	145	M27x2	25	28	117	170	29	45	82	249
	45	45								M33x2		36						
80	45	45	85	85	130	95	3/4"G	17,5	165	M33x2	32	36	134	195	36	54	91	282
	56	56								M42x2		46						
100	56	56	106	106	158	115	1"G	22	200	M42x2	32	46	162	238	37	57	108	332
	70	63								M48x2		60						
125	70	63	132	132	192	145	1"G	22	235	M48x2	32	60	174	272	37	60	121	357
	90	85								M64x3		75						
160	90	85	160	160	232	185	1 1/4"G	22	280	M64x3	36	75	191	316	41	66	143	406
	110	95								M80x3		90						
200	110	95	200	200	285	230	1 1/4"G	26	340	M80x3	40	90	224	385	45	75	190	490
	140	112								M100x3		120						
250	140	112	250	250	365	298	1 1/2"G	33	420	M100x3	56	120	290	500	64	96	205	606
	180	125								M125x4		160						
320	180	125	320	320	450	368	1 1/2"G	39	520	M125x4	63	160	358	620	71	108	250	723
	220	160								M160x4		200						

CILCOIL, S.A. - se reserva el derecho de modificar: Técnica, material, cotas y formas sin previo aviso.

CILCOIL, S.A. - reserves the rights to modify: Techniques, materials, dimensions and shapes without prior notice.

Volver  
Series Fabricación

Volver  
Página Principal

