

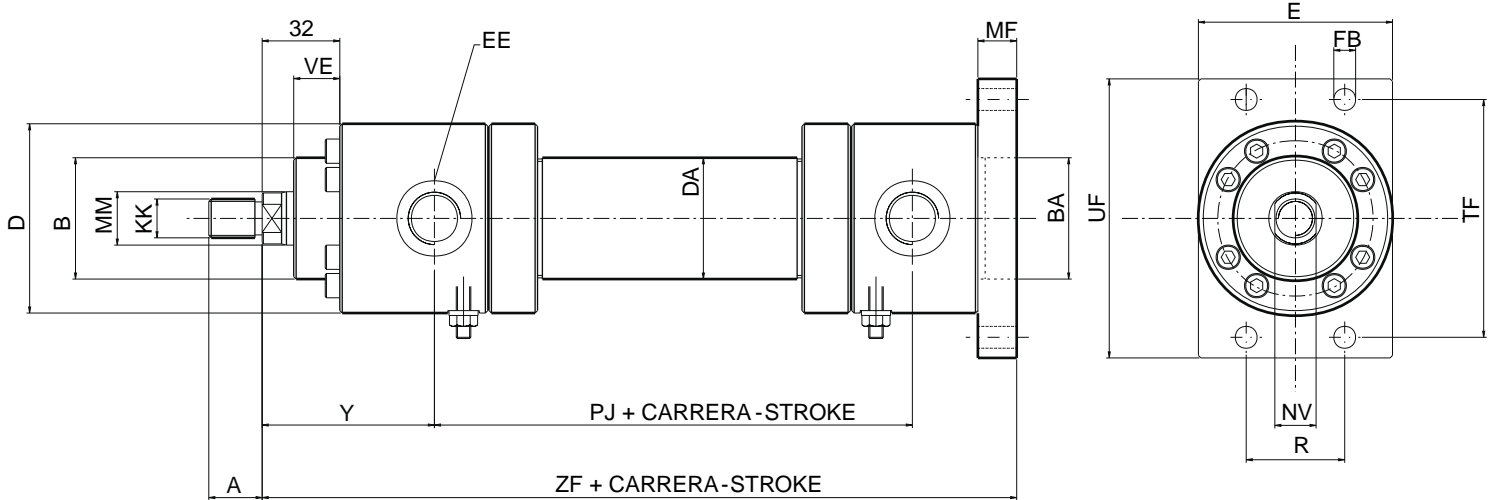

• TIPO - TYPE: PS - MF2 •
BRIDA TRASERA CIRCULAR
CAP CIRCULAR FLANGE MOUNTING



PISTON BORE	MM	A	B _{f8}	BA _{H8}	D	DA	E	EE	FB _{H13}	KK	MF	NV	PJ	R _{js13}	TF _{js13}	UF	VE	WF	Y	ZF
25	14	16	32	32	56	35	60	1/4"G	6,6	M12x1.25	12	12	77	28,7	69,2	85	15	28	58	162
	18	18								M14x1.5		15								
32	18	18	40	40	67	42	70	3/8"G	9	M14x1.5	16	15	89	35,2	85	105	19	32	64	186
	22	22								M16x1.5		17								
40	22	22	50	50	78	50	80	1/2"G	9	M16x1.5	16	17	97	40,6	98	115	19	32	71	206
	28	28								M20x1.5		22								
50	28	28	60	60	95	60	100	1/2"G	11	M20x1.5	20	22	111	48,2	116,4	140	24	38	72	225
	36	36								M27x2		28								
63	36	36	70	70	116	75	120	3/4"G	13,5	M27x2	25	28	117	55,5	134	160	29	45	82	249
	45	45								M33x2		36								
80	45	45	85	85	130	95	135	3/4"G	17,5	M33x2	32	36	134	63,1	152,5	185	36	54	91	282
	56	56								M42x2		46								
100	56	56	106	106	158	115	160	1"G	22	M42x2	32	46	162	76,5	184,8	225	37	57	108	332
	70	63								M48x2		60								
125	70	63	132	132	192	145	195	1"G	22	M48x2	32	60	174	90,2	217,1	255	37	60	121	357
	90	85								M64x3		75								

CILCOIL, S.A. - se reserva el derecho de modificar: Técnica, material, cotas y formas sin previo aviso.

CILCOIL, S.A. - reserves the rights to modify: Techniques, materials, dimensions and shapes without prior notice.

