

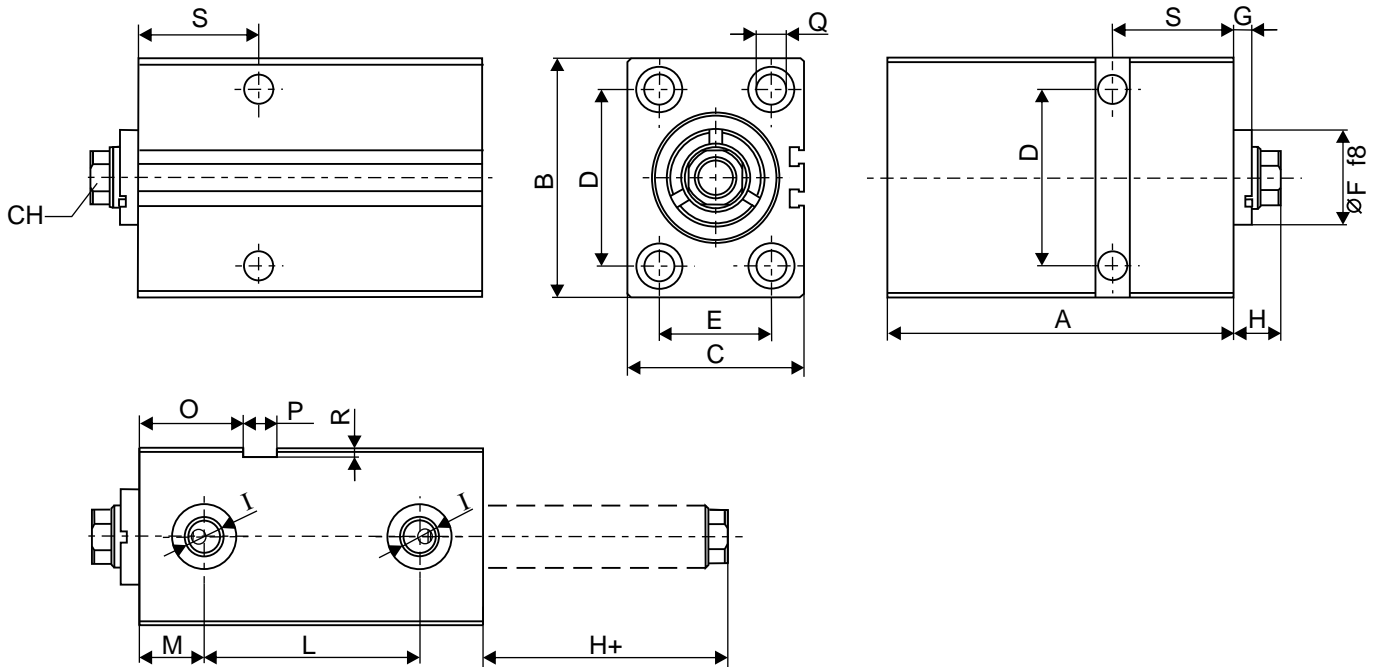

VERSIÓN BÁSICA X  
BASIC VERSION X



<b>Pistón Piston</b>	25		32		40		50		63		80		100	
<b>Vástago Rod</b>	18		22		22		28		28		36		45	
<b>Carrera Stroke</b>	20	50	20	50	20	50	20	50	20	50	20	50	20	50
<b>A</b>	77	107	80	110	93	123	95	125	105	135	120	150	130	160
<b>B</b>	65		75		85		100		115		140		170	
<b>C</b>	45		55		63		75		90		110		140	
<b>CH</b>	14		18		18		24		22		30		36	
<b>D</b>	50		55		63		76		90		110		135	
<b>E</b>	30		35		40		45		55		75		95	
<b>F f8</b>	30		34		34		42		50		60		72	
<b>G</b>	6,5		8		7		8		7		7		8	
<b>H</b>	14		15		17		20		20		20		25	
<b>I</b>	G1/4		G1/4		G1/4		G1/4		G3/8		G1/2		G1/2	
<b>L</b>	43	73	44	74	46	76	48	78	53	83	60	90	60	90
<b>M</b>	17		18		23,5		23,5		26		30		35	
<b>N</b>	M10		M12		M14		M20		M20		M27		M33	
<b>O</b>	32		34		37		37		47,5		50		60	
<b>P</b>	10		12		12		15		15		20		20	
<b>Q</b>	8,5		10,5		10,5		13		13		17		17	
<b>R</b>	2		3		3		5		5		5		5	
<b>S</b>	37		40		43		45		55		60		70	
<b>W</b>	23		23		30		35		30		40		50	